

13 Write $\frac{3}{50}$ as a percentage.

$$\frac{3}{50} = \frac{6}{100}$$

.....
6 %

(Total for Question 13 is 1 mark)

14 Write 0.06 as a percentage.

$$0.06 \times 100$$

.....
6 %

(Total for Question 14 is 1 mark)

15 Write 0.11 as a fraction.

$$\frac{11}{100}$$

.....
(Total for Question 15 is 1 mark)

16 Write 0.9 as a percentage.

$$0.9 \times 100$$

.....
90 %

(Total for Question 16 is 1 mark)

17 Write 0.19 as a percentage.

$$0.19 \times 100$$

.....
19 %

(Total for Question 17 is 1 mark)

18 Write 0.025 as a fraction.

$$\frac{25}{1000} \text{ or } \frac{5}{200} \text{ or } \frac{1}{40}$$

$$\frac{25}{1000}$$

any equivalent

.....
(Total for Question 18 is 1 mark)

19 Write $\frac{12}{100}$ as a decimal.

$$12 \div 100$$

0.12

(Total for Question 19 is 1 mark)

20 Write $\frac{7}{10}$ as a decimal.

$$7 \div 10$$

0.7

(Total for Question 20 is 1 mark)

21 Write 0.003 as a fraction.

$$\frac{3}{1000}$$

(Total for Question 21 is 1 mark)

22 Write 0.3 as a percentage.

$$0.3 \times 100$$

30 %

(Total for Question 22 is 1 mark)

23 Write $\frac{9}{20}$ as a percentage.

$$\frac{9}{20} = \frac{45}{100}$$

45 %

(Total for Question 23 is 1 mark)

24 Write 0.06 as a fraction.

$$\frac{6}{100}$$

(Total for Question 24 is 1 mark)

25 Dean says that 13% is greater than 0.1

Is Dean correct?

Give a reason for your answer.

YES : either $13\% = 0.13$ and $0.13 > 0.1$

or $0.1 = 10\%$ and $13\% > 10\%$

(Total for Question 25 is 1 mark)

26 Tom and Jerry both earn the same monthly salary.

Each month:

Tom saves 35% of his salary.

Jerry spends $\frac{3}{5}$ of his salary and saves the rest of his salary.

Work out who saves the most money each month.

You must show your working.

Jerry saves $\frac{2}{5} = 40\%$

$40\% > 35\%$

Jerry saves more money.

(Total for Question 26 is 2 marks)

27 Write the following numbers in order of size.

Start with the smallest number.

75% $\frac{7}{10}$ 0.72 0.9 $\frac{4}{5}$

0.75 0.7 0.8

$\frac{7}{10}$ 0.72 75% $\frac{4}{5}$ 0.9

(Total for Question 27 is 2 marks)

28 Write the following numbers in order of size.

Start with the smallest number.

0.3 $\frac{1}{3}$ 21% $\frac{1}{4}$ 0.205

30% 33.3% 25% 20.5%

0.205 21% $\frac{1}{4}$ 0.3 $\frac{1}{3}$

(Total for Question 28 is 2 marks)

- 1 Emma buys a house for £201 500
She sells the house for £213 590

Calculate the percentage profit Emma makes.

$$\frac{\text{change}}{\text{original}} \times 100$$

$$\frac{213590 - 201500}{201500} \times 100$$

$$= 6\%$$

.....6.....%

(Total for question 1 is 3 marks)

- 2 Mel buys a house for £352 000
She sells the house for £325 600

Calculate the percentage loss Mel makes.

$$\frac{\text{change}}{\text{original}} \times 100$$

$$\frac{325600 - 352000}{352000} \times 100$$

$$= -7.5\%$$

.....7.5.....%

(Total for question 2 is 3 marks)

- 3 Last year Geri's council tax bill was £1815
This year she has to pay £1906 for her council tax.
Work out the percentage increase in her council tax bill.
Give your answer to 1 decimal place.

$$\frac{1906 - 1815}{1815} \times 100$$

$$5.01377... \%$$

..... 5.0

(Total for question 3 is 3 marks)

- 4 Last year Victoria paid £354 for her car insurance.
This year she has to pay £329 for her car insurance.
Work out the percentage decrease in her car insurance.
Give your answer to 1 decimal place.

$$\frac{329 - 354}{354} \times 100$$

$$= -7.06214... \%$$

..... 7.1

(Total for question 4 is 3 marks)

- 5 In 2000, the world population was 6.1 billion.
In 2015, the world population was 7.3 billion.

Work out the percentage increase in population.
Give your answer correct to 1 decimal place.

$$\frac{7.3 - 6.1}{6.1} \times 100$$

$$19.6721... \%$$

$$\dots\dots\dots 19.7 \dots\dots\dots \%$$

(Total for question 5 is 3 marks)

- 6 Banana computers sold 19.3 million computers in 2017.
In 2018, they sold 18.2 million computers.

Work out the percentage decrease in the number of computers sold.
Give your answer to three significant figures.

$$\frac{18.2 - 19.3}{19.3} \times 100$$

$$= -5.69948... \%$$

$$\dots\dots\dots 5.70 \dots\dots\dots \%$$

(Total for question 6 is 3 marks)

- 7 Last year Patrick paid £2534 for his annual train ticket.
This year he has to pay £2612 for his annual train ticket.

Work out the percentage increase in the cost of his train ticket.
Give your answer correct to 3 significant figures.

$$\frac{2612 - 2534}{2534} \times 100$$

$$3.078137... \%$$

$$\dots\dots\dots 3.08 \dots\dots\dots \%$$

(Total for question 7 is 3 marks)

- 8 The average house price in London in 2017 was £474902
The average house price in London in 2018 was £469538

Calculate the percentage change in house prices between 2017 and 2018.
Give your answer correct to 1 decimal place.

$$\frac{469538 - 474902}{474902} \times 100$$

$$= -1.129496... \%$$

$$\dots\dots\dots -1.1 \dots\dots\dots \%$$

(Total for question 8 is 3 marks)

- 9 Richard buys a car for £13 500
He sells the car for £9 500

Work out Richard's percentage loss.
Give your answer correct to three significant figures.

$$\frac{9500 - 13500}{13500} \times 100$$
$$= -29.6296\ldots\%$$

..... 29.6 %

(Total for question 9 is 3 marks)

- 10 Lottie buys a pack of 50 cans of lemonade.
She pays £17 for the cans.

Lottie sells 32 of the cans for 50p each.
She sells the remaining cans for 20p each.

$$32 \times 0.5 = 16$$
$$18 \times 0.2 = 3.6$$

Work out Lottie's percentage profit.
Give your answer correct to three significant figures.

$$\underline{\underline{£ 19.60}}$$

$$\frac{19.60 - 17}{17} \times 100$$
$$= 15.2941\ldots\%$$

..... 15.3 %

(Total for question 10 is 3 marks)

- 11 Karen buys a pack of 8 bottles of water.
The pack costs £1.25

Karen sells all 8 bottles of water for 50p each.

$$8 \times 0.5 = 4$$

Work out Karen's percentage profit.

$$\frac{4 - 1.25}{1.25} \times 100$$

.....220.....%

(Total for question 11 is 3 marks)

- 12 Theo buys 24 packs of crisps.
He pays £3 for the crisps.

Theo sells each pack of crisps for 50p.

$$24 \times 0.5 = 12$$

Work out Theo's percentage profit.

$$\frac{12 - 3}{3} \times 100$$

.....300.....%

(Total for question 12 is 3 marks)

- 13 Donald buys a pack of 9 chocolate bars.
The pack costs £2.50

Donald sells all 9 chocolate bars for 45p each.

$$9 \times 0.45 = 4.05$$

Work out Donald's percentage profit.

$$\frac{4.05 - 2.50}{2.50} \times 100$$

.....62.....%

(Total for question 13 is 3 marks)

- 14 Alan buys 1.2 kg of sweets. 1200g
He pays £2.25 for the sweets.

Alan puts the sweets into bags.
He puts 150g of sweets in each bag.
He sells each bag of sweets for 30p.

$$\frac{1200}{150} = 8 \text{ bags}$$

Work out Alan's percentage profit.

$$8 \times 0.3 = 2.4$$

$$\frac{2.4 - 2.25}{2.25} \times 100$$

6.6%

.....6.6.....%

[or 6.7/6.67%]

(Total for question 14 is 4 marks)

1 Jesy invests £8000 for n years in a savings account.

To find the value, V , of her investment after n years she uses the formula:

$$V = 8000 \times (1.025)^n$$

(a) Write down the annual rate of interest Jesy earns.

..... 2.5%

(1)

(b) Find the **total amount of interest** Jesy earns in three years.

$$8000 \times 1.025^3 = \pounds 8615.13$$

$$8615.13 - 8000$$

..... \pounds 615.13

(2)

(Total for question 1 is 3 marks)

2 Perrie invests £25000 for 3 years in a savings account.
She gets 2.7% per annum compound interest.

Calculate the **total amount of interest** Perrie will get after 3 years.

$$25000 \times 1.027^3 = 27080.17$$

$$27080.17 - 25000 = \pounds 2080.17$$

..... \pounds 2080.17

(Total for question 2 is 3 marks)

3 Jade bought a house for £350 000.

In the first year the house price increased by 3%
In the second year the house price increased by 2%
In the third year the house price depreciated by 5%

Work out the value of the house at the end of 3 years.

$$350\,000 \times 1.03 \times 1.02 \times 0.95$$

$$= \text{£ } 349\,324.50$$

£ 349 324.50

(Total for question 3 is 3 marks)

4 Leigh-Anne invests £2500 for 4 years in a savings account.
She gets 3% per annum compound interest.

How much money does Leigh-Anne have at the end of 4 years.

$$2500 \times 1.03^4 = \text{£ } 2813.77$$

£ 2813.77

(Total for question 4 is 2 marks)

- 5 Annie invests £9500 for 5 years in a savings account.
She gets 1.8% per annum compound interest.

How much money does Annie have at the end of 5 years.

$$9500 \times 1.018^5 = £10386.34$$

£.....10386.34.....

(Total for question 5 is 2 marks)

- 6 Greg bought a new car for £18000.
In the first year the value of the car depreciates by 30%.
In the second year and the third year the car depreciates by 14%

Work out the value of the car after three years.

$$18000 \times 0.7 \times 0.86^2 = £9318.96$$

£.....9318.96.....

(Total for question 6 is 3 marks)

- 7 Nick bought a new car.
Each year the car depreciates in value by 12%.

Work out the number of years it takes for the car to half in value.

$$0.88^2 = 0.7744$$

$$0.88^3 = 0.681472$$

$$0.88^4 = 0.59969536$$

$$0.88^5 = 0.5277319168$$

$$0.88^6 = 0.464404868 \quad [\text{less than } 0.5]$$

.....6.....years

(Total for question 7 is 3 marks)

- 8 Fearnie invests £5600 in a savings account.
She gets 2% per annum compound interest.

After n years, Fearnie has £6061.62 in her account.
Work out the value of n .

$$5600 \times 1.02^3 = \begin{matrix} 5942.76 \\ \hline \cancel{6119.27} \end{matrix}$$

$$5600 \times 1.02^4 = 6061.62 \quad \checkmark$$

.....4.....

(Total for question 8 is 2 marks)

9 Alice is going to invest some money for 5 years.

She can choose from ~~of~~ two options:

Investment A: 2.7% compound interest per annum

Investment B: 2.8% simple interest per annum

Which investment should Alice choose
You must show your working.

A

$$100 \times 1.027^5 = 114.2$$

Increase of 14.2%

B

$$2.8 \times 5 = 14$$

Increase of 14%

She should choose investment A

(Total for question 9 is 4 marks)

10 Matt wants to invest £8000 for three years. He can choose between Bank A and Bank B.

Bank A

1.2% compound interest
per annum

Bank B

2% compound interest in
the first year
1% compound interest
for each extra year

Which bank will give Matt the most interest after three years.
You must show your working.

A

$$\begin{aligned} & \cancel{8000 \times 1.02^3} \\ & 8000 \times 1.012^3 \\ & = \pounds 8291.47 \end{aligned}$$

B

$$\begin{aligned} & 8000 \times 1.02 \times 1.01^2 \\ & = \pounds 8324.02 \end{aligned}$$

Bank B

(Total for question 10 is 4 marks)

11 Melvin invests £5000 in an account paying 2.5% compound interest per annum.

Charlie invests £4500 in an account paying 3% compound interest per annum.

Work out the difference between the amount of money Melvin has after 5 years and the amount of money Charlie has after 5 years.

$$\text{Melvin: } 5000 \times 1.025^5 = 5657.04$$

$$\text{Charlie: } 4500 \times 1.03^5 = 5216.73$$

$$5657.04 - 5216.73$$

$$= 440.31$$

£.....440.31.....

(Total for question 11 is 4 marks)

- 1 Write down the ratio of 350 cm to 25 cm.
Give your answer in its simplest form.

$$\begin{array}{r} 350 : 25 \\ \div 25 \quad \div 25 \\ \hline 14 : 1 \end{array}$$

$$14 : 1$$

(Total for question 1 is 2 marks)

- 2 Write down the ratio of 220 kg to 5 kg.
Give your answer in its simplest form.

$$\begin{array}{r} 220 : 5 \\ \div 5 \quad \div 5 \\ \hline 44 : 1 \end{array}$$

$$44 : 1$$

(Total for question 2 is 2 marks)

- 3 Alex has the following coins:



Write down the ratio of the value of Alex's 20p coins to the value of Alex's 50p coins.

$$\begin{array}{r} 40 : 150 \\ \hline 4 : 15 \end{array}$$

$$4 : 15$$

(Total for question 3 is 2 marks)

- 4 (a) Write the ratio 32 : 24 in its simplest form

$$\div 8 \quad \div 8$$

$$4 : 3$$

$$\frac{4 : 3}{\dots\dots\dots}$$

(1)

- (b) $\frac{1}{9}$ of people in a class are left handed.

Write the ratio of left handed people to right handed people

$$\frac{1}{9} : \frac{8}{9}$$

$$1 : 8$$

$$\frac{1 : 8}{\dots\dots\dots}$$

(1)

(Total for question 7 is 2 marks)

- 5 (a) Write the ratio 15 : 35 in its simplest form.

$$\div 5 \quad \div 5$$

$$3 : 7$$

$$\frac{3 : 7}{\dots\dots\dots}$$

(1)

- (b) There are red shapes and blue shapes in a box, $\frac{2}{3}$ of the shapes are red.

Write the ratio of red shapes to blue shapes.

$$\frac{2}{3} : \frac{1}{3}$$

$$2 : 1$$

$$\frac{2 : 1}{\dots\dots\dots}$$

(1)

(Total for question 9 is 2 marks)

- 6 (a) Write the ratio 81 : 27 in its simplest form

$$\div 9 \quad \div 9$$

$$9 : 3$$

$$\div 3 \quad \div 3$$

$$3 : 1$$

$$\begin{array}{r} 3 : 1 \\ \hline \end{array} \quad (1)$$

- (b) $\frac{3}{8}$ of chocolates in a box are white chocolate, the rest are milk chocolate.

Write the ratio of white chocolates to milk chocolates.

$$\frac{3}{8} : \frac{5}{8}$$

$$3 : 5$$

$$\begin{array}{r} 3 : 5 \\ \hline \end{array} \quad (1)$$

(Total for question 6 is 2 marks)

- 7 (a) Write the ratio 24 : 72 in its simplest form.

$$\div 8 \quad \div 8$$

$$3 : 9$$

$$1 : 3$$

$$\begin{array}{r} 1 : 3 \\ \hline \end{array} \quad (1)$$

- (b) In February, it rained on $\frac{3}{7}$ of days

Write the ratio of the days it rained to the number of days it did not rain.

$$\frac{3}{7} : \frac{4}{7}$$

$$3 : 4$$

$$\begin{array}{r} 3 : 4 \\ \hline \end{array} \quad (1)$$

(Total for question 9 is 2 marks)

8 Write the ratio $7.5 : 2.5$ in the form $n : 1$

$$\div 2.5 \quad \div 2.5$$

$$3 : 1$$

$$3 : 1$$

(Total for question 8 is 1 mark)

9 Write the ratio $12 : 30$ in the form $1 : n$

$$6 : 15$$

$$2 : 5$$

$$1 : 2.5$$

$$1 : 2.5$$

(Total for question 9 is 1 mark)

10 There are some cubes in a bag.

$\frac{1}{6}$ of the cubes are red.

The rest of the cubes are blue.

Write the ratio of the number of red cubes to the number of blue cubes.

Give your answer in the form $1 : n$

$$\frac{1}{6} : \frac{5}{6}$$

$$1 : 5$$

$$1 : 5$$

(Total for question 10 is 2 marks)

11 There are only blue counters, red counters and yellow counters in a bag.

There are twice as many blue counters as yellow counters.

There are three times as many red counters as yellow counters.

$$B : Y$$

$$2 : 1$$

$$R : Y$$

$$3 : 1$$

Write down the ratio of blue counters to red counters to yellow counters.

$$B : R : Y$$

$$2 : 3 : 1$$

(Total for question 11 is 2 marks)

12 There are only green pens, black pens and red pens in a box.

There are four times as many green pens as black pens. $4 : 1$

There are twice as many red pens as green pens. $4 : 8$

Write down the ratio of green pens to black pens to red pens.

$$G : B : R$$

$$4 : 1 : 8$$

$$4 : 1 : 8$$

(Total for question 12 is 2 marks)

- 13 Charlotte, Jo and Mike played a game.

Charlotte's scored four times as many points as Jo.
Mike's scored half as many points as Charlotte.

Write down the ratio of Charlotte's points to Jo's points to Mike's points

$$C : J : M$$
$$4 : 1 : 2$$

$$4 : 1 : 2$$

(Total for question 13 is 2 marks)

- 14 There are 120 people in a school canteen.
Half of the people in the canteen are in year 11 students. 60

The number of year 11 students in the canteen is three times the number of year 10 students.
The rest of the people in the canteen are year 9 students.

$$\frac{60}{3} = 20$$

the number of year 9 students : the number of year 10 students = $n : 1$

Work out the value of n .
You must show how you get your answer.

$$120 - 60 - 20 = 40 \quad \text{YEAR 9}$$

$$40 : 20$$
$$2 : 1$$

$$n = 2$$

(Total for question 14 is 2 marks)

15 In a bag there are blue sweets, red sweets and yellow sweets.

The number of red sweets is three times the number of blue sweets.
The number of yellow sweets is half the number of red sweets.

Write down the ratio of blue sweets to red sweets to yellow sweets.
Give your answer in the form $a : b : c$ where a , b and c are whole numbers

$$\begin{aligned} B &: R : Y \\ 1 &: 3 : 1.5 \\ 2 &: 6 : 3 \end{aligned}$$

$$2 : 6 : 3$$

(Total for question 15 is 2 marks)

16 In a bag there are blue sweets, red sweets and yellow sweets.

The number of blue sweets is four times the number of yellow sweets.
The number of red sweets is half the number of yellow sweets.

Find the percentage of sweets in the bag that are yellow.

$$\begin{aligned} B &: R : Y \\ 4 &: 0.5 : 1 \\ 8 &: 1 : 2 \end{aligned}$$

Yellow $\frac{2}{11}$

$$\frac{2}{11} \times 100$$

$$\frac{200}{11} \dots \%$$

(Total for question 16 is 2 marks)

$$18.18\%$$

1 A machine fills 1000 bottles in 5 hours.

Work out how many hours it would take the machine to fill 1200 bottles.

$$\begin{array}{l}
 1000 \text{ bottles in } 5 \text{ hours} \downarrow \\
 \qquad \qquad \qquad \qquad \qquad \qquad \div 5 \\
 200 \text{ bottles in } 1 \text{ hour} \downarrow \\
 \qquad \qquad \qquad \qquad \qquad \qquad \downarrow \\
 \qquad \qquad \qquad \qquad \qquad \qquad \times 6 \\
 1200 \text{ bottles in } 6 \text{ hours} \downarrow
 \end{array}$$

6

(Total for question 1 is 2 marks)

2 It costs £0.75 to buy 5 bananas.

Work out how much it would cost to buy 7 bananas.

$$\begin{array}{l}
 £0.75 \text{ for } 5 \text{ bananas} \downarrow \\
 \qquad \qquad \qquad \qquad \qquad \qquad \div 5 \\
 £0.15 \text{ for } 1 \text{ banana} \downarrow \\
 \qquad \qquad \qquad \qquad \qquad \qquad \downarrow \\
 \qquad \qquad \qquad \qquad \qquad \qquad \times 7 \\
 £1.05 \text{ for } 7 \text{ bananas} \downarrow
 \end{array}$$

£1.05

(Total for question 2 is 2 marks)

3 3 tins of beans and 4 tins of tomatoes costs £2.73.

5 tins of beans costs £1.55.

Work out how much one tin of tomatoes costs.

5 tins of beans costs £1.55
↓ ÷ 5

1 tin of beans costs £0.31

3 tins of beans costs £0.93
↓ × 3

$$2.73 - 0.93 = \pounds 1.80$$

£1.80 for 4 tins of tomatoes

$$\pounds 1.80 \div 4 = \pounds 0.45$$

£0.45

(Total for question 3 is 2 marks)

4 There are 500 sheets in a pack of paper. 500 sheets of paper weigh 2.5kg.

Work out the weight of 50 sheets of paper.

500 sheets weigh 2.5kg
↓ ÷ 10

↓

50 sheets weigh 0.25kg

0.25kg

(Total for question 4 is 2 marks)

5 It takes 2 painters 4 days to complete a job.

Inverse proportion.
More painters = Less time.

Work out how many days it would take 1 painter to complete the same job.

2 painters take 4 days

$2 \times 4 = 8$ 8 days of work needed.

8

(Total for question 5 is 2 marks)

6 It takes 3 machines 2 days to produce a batch of products

Work out how long it would take 1 machine to produce the same batch of products.

$$3 \times 2 = 6$$

6 days of machine work needed

6

(Total for question 6 is 2 marks)

7 It takes 3 painters 6 days to complete a job.

Work out how many days it would take 2 painters to complete the same job.

$$3 \times 6 = 18$$

18 days of work needed

$$2 \text{ painters} \quad \frac{18}{2} = 9 \text{ days}$$

9

(Total for question 7 is 2 marks)

8 It takes 5 machines 6 hours to produce 1000 DVDs

Work out how long it would take 4 machines to produce 1000 DVDs.

$$5 \times 6 = 30 \text{ machine } \overset{\text{hours}}{\text{days}} \text{ needed}$$

$$\frac{30}{4} = 7.5 \text{ hours}$$

7.5 hours

(Total for question 8 is 2 marks)

9 x is inversely proportional to y .

x is given by the formula: $x = \frac{1000}{y}$

Find the value of x when $y = 50$

$$x = \frac{1000}{y}$$

$$x = \frac{1000}{50} = 20$$

$$x = \dots 20 \dots$$

(Total for question 9 is 2 marks)

10 y is directly proportional to x .

y is given by the formula: $y = 0.4x$

Find the value of y when $x = 6$

$$y = 0.4x$$

$$y = 0.4(6)$$

$$y = 2.4$$

$$y = \dots 2.4 \dots$$

(Total for question 10 is 2 marks)

- 11 The weight of a piece of wire (w grams) is directly proportional to its length (l cm).

w is given by the formula: $w = 30l$

Find the length of a wire weighing 75 grams.

$$\begin{aligned}w &= 30l \\75 &= 30l \\ \frac{75}{30} &= l \\ l &= 2.5\end{aligned}$$

$$l = \dots 2.5 \dots \text{cm}$$

(Total for question 11 is 2 marks)

- 12 The force, F , between two magnets is inversely proportional to the square of the distance, x cm, between them.

F is given by the formula: $F = \frac{36}{x^2}$

Find the Force when two magnets are 3 cm apart.

$$\begin{aligned}F &= \frac{36}{x^2} \\ &= \frac{36}{3^2} \\ &= \frac{36}{9} \\ &= 4\end{aligned}$$

$$F = \dots 4 \dots \text{N}$$

(Total for question 12 is 2 marks)

13 Here are four graphs.

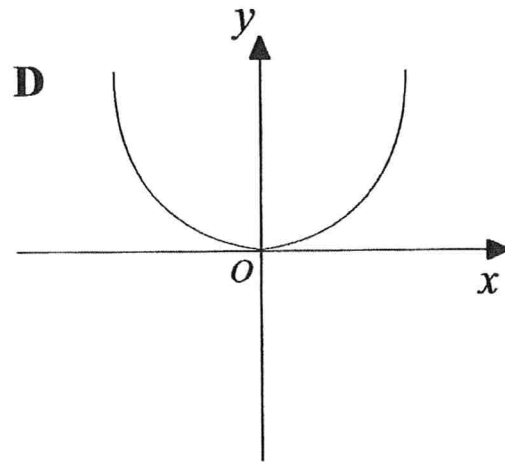
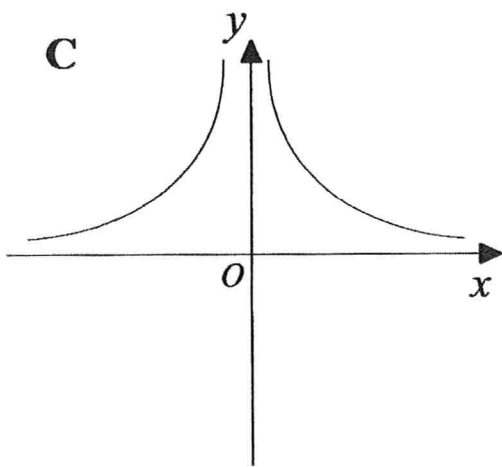
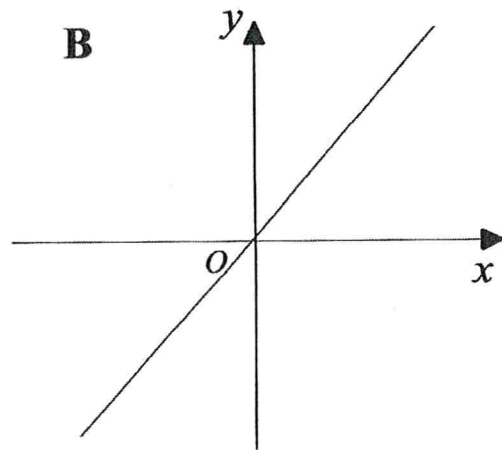
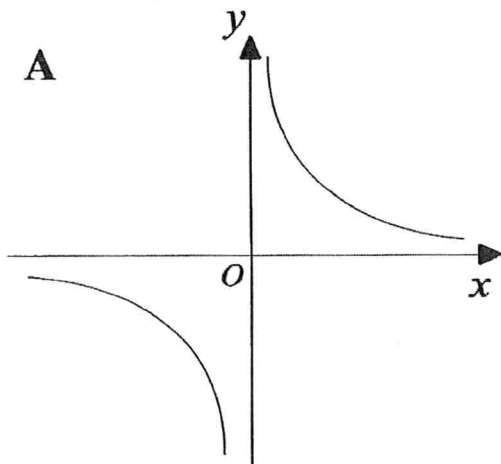

Match each graph with a statement in the table below.

Proportionality relationship	Graph letter
y is directly proportional to x	B
y is inversely proportional to x	A
y is directly proportional to x^2	D
y is inversely proportional to x^2	C

(Total for question 13 is 2 marks)

- 1 (a) On the diagram below, draw a radius of the circle.

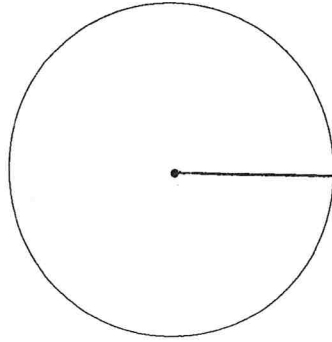

- (b) On the diagram below, draw a sector of the circle. Shade the sector.

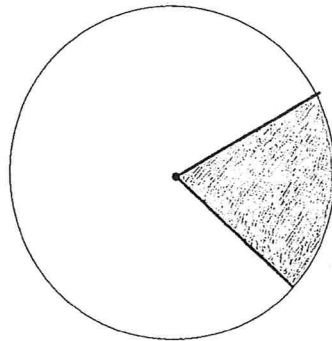

(Total for question 1 is 2 marks)

- 2 (a) Write down the mathematical name for the straight line touching the circle.

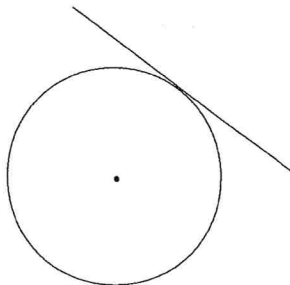

.....tangent.....

- (b) Write down the mathematical name for the straight line shown in the diagram.

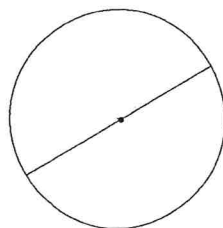

.....diameter.....

(Total for question 2 is 2 marks)

- 3 A circle has a radius of 6.5 cm.
Work out the circumference of the circle.
Give your answer correct to 2 decimal places.

$$\begin{aligned} \text{Circumference} &= 2\pi r \\ &= 2\pi(6.5) \\ &= 13\pi \\ &= 40.84 \text{ cm} \end{aligned}$$

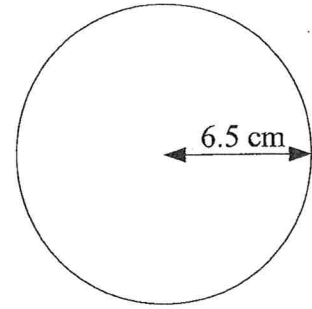

.....40.84 cm.....

(Total for question 3 is 3 marks)

- 4 A circle has a diameter of 9 m. Radius = 4.5
Work out the area of the circle.
Give your answer correct to 1 decimal place.

$$\begin{aligned} \text{Area} &= \pi r^2 \\ &= \pi(4.5)^2 \\ &= \frac{81}{4}\pi \\ &= 63.6 \text{ m}^2 \end{aligned}$$

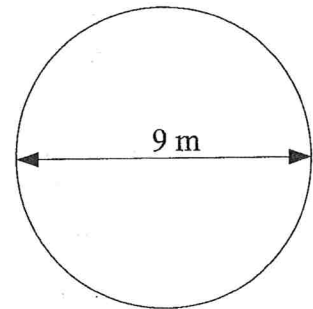

.....63.6 m².....

(Total for question 4 is 3 marks)

- 5 A circle has a diameter of 12 mm.
Work out the circumference of the circle.
Give your answer in terms of π .

$$\begin{aligned} \text{Circumference} &= \pi d \\ &= \pi(12) \\ &= 12\pi \end{aligned}$$

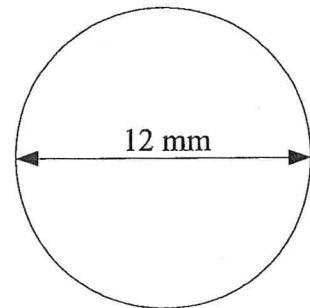

.....12 π mm.....

(Total for question 5 is 3 marks)

- 6 A circle has a radius of 8 cm.
Work out the area of the circle.
Give your answer in terms of π .

$$\begin{aligned} \text{Area} &= \pi r^2 \\ &= \pi(8)^2 \\ &= 64\pi \end{aligned}$$

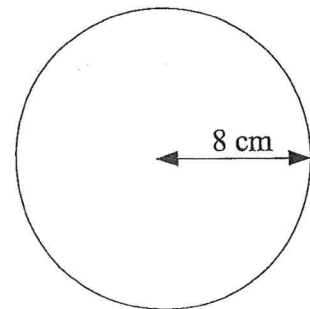

.....64 π cm².....

(Total for question 6 is 3 marks)

- 7 A semi-circle has an area of 50 m^2 .
Find the perimeter of the semi-circle.
Give your answer correct to one decimal place.

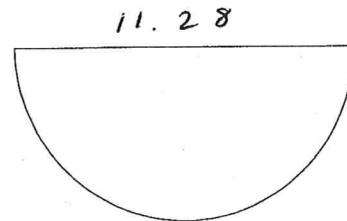

$$\text{Area of semi circle} = \frac{\pi r^2}{2}$$

$$\frac{\pi r^2}{2} = 50$$

$$\pi r^2 = 100$$

$$r^2 = \frac{100}{\pi}$$

$$r = \sqrt{\frac{100}{\pi}}$$

$$= 5.64189\dots$$

$$\begin{aligned} \text{diameter} &= 5.64189 \times 2 \\ &= 11.28379\dots \end{aligned}$$

$$\begin{aligned} \text{circumference} &= \pi d \\ (\text{whole circle}) &= \pi (11.28) \\ &= 35.449\dots \end{aligned}$$

$$\frac{35.449}{2} = 17.72\dots$$

$$11.28 + 17.72 = \underline{\underline{29.0}}$$

..... 29.0 m

(Total for question 7 is 4 marks)

- 8 A circular field has a diameter of 32 metres.
A farmer wants to build a fence around the edge of the field.
Each metre of fence will cost £15.95
Work out the total cost of the fence.

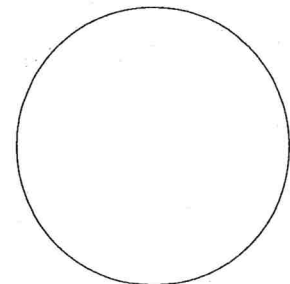

$$\begin{aligned} \text{Circumference} &= \pi d \\ &= \pi (32) \\ &= 32\pi \text{ m} \end{aligned}$$

$$32\pi \times 15.95 = \pounds 1603.47$$

£..... 1603.47

(Total for question 8 is 3 marks)

9

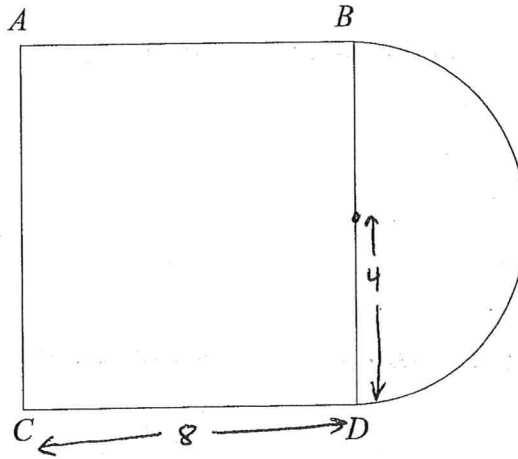

An area is formed by a square, $ABCD$, and a semi circle.
 BD is the diameter of the semi circle.

The radius of the semi circle is 4m. $diameter = 8m$

The area is going to be covered completely with lawn seed.

A box of lawn seed covers $25 m^2$.

How many boxes of lawn seed will be needed?
 You must show your working.

$$\begin{aligned} \text{Area of square} &= 8 \times 8 \\ &= 64 m^2 \end{aligned}$$

$$\begin{aligned} \text{Area of semi-circle} &= \frac{\pi r^2}{2} \\ &= \frac{\pi (4)^2}{2} \\ &= 8\pi \\ &= 25.1 m^2 \end{aligned}$$

$$64 + 25.1 = \underline{89.1 m^2}$$

$$75 m^2 = 3 \text{ boxes}$$

$$100 m^2 = 4 \text{ boxes}$$

.....
 4

(Total for question 9 is 5 marks)

- 10 The diagram shows a shaded ring formed by cutting a smaller circle out of a larger circle.

The radius of the smaller circle is 6 cm.
The diameter of the larger circle is 15 cm.

$$r = 7.5$$

Find the area of the shaded ring.

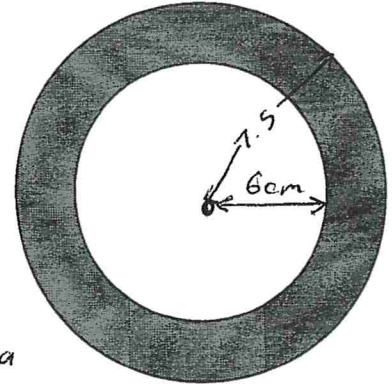

$$\text{Shaded Area} = \text{Large Area} - \text{Small Area}$$

$$= \pi (7.5)^2 - \pi (6)^2$$

$$= \frac{81}{4} \pi \quad \text{or} \quad 63.6 \text{ cm}^2$$

$$\dots\dots\dots \frac{81}{4} \pi \dots\dots\dots \text{cm}^2$$

(Total for question 10 is 3 marks)

- 11 The diagram shows three quarters of a circle with a radius of 12 metres.

Find the perimeter of the shape.

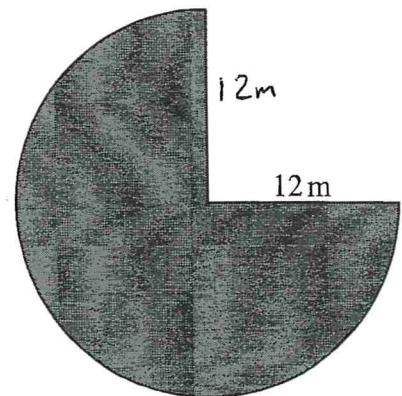

$$\begin{aligned} \text{Circumference (whole circle)} &= 2\pi r \\ &= 2\pi(12) \\ &= 24\pi \end{aligned}$$

$$\frac{3}{4} \times 24\pi = 18\pi$$

$$\begin{aligned} \text{perimeter} &= 18\pi + 12 + 12 \\ &= 80.55 \text{ m (2dp)} \end{aligned}$$

$$\dots\dots\dots 80.55 \dots\dots\dots \text{m}$$

(Total for question 11 is 3 marks)

12 The diagram shows a semi circle inside a sector of a circle, ABC .

AB is the diameter of the semi circle.
 Angle $BAC = 90^\circ$
 $AB = 12 \text{ cm}$

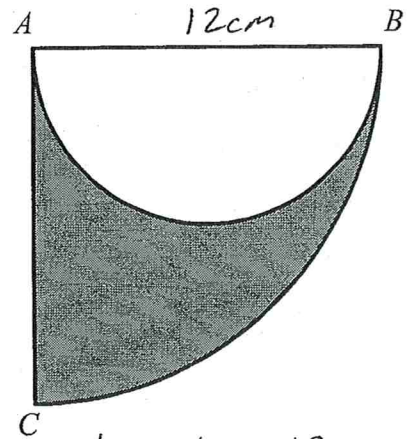

Find the area of the shaded region.

Radius of semi-circle = 6cm

$$\begin{aligned} \text{Area of semi circle} &= \frac{\pi r^2}{2} \\ &= \frac{\pi (6)^2}{2} \\ &= 18\pi \end{aligned}$$

Radius of $\frac{1}{4}$ circle = 12cm

$$\begin{aligned} \text{Area of } \frac{1}{4} \text{ circle} &= \frac{\pi r^2}{4} \\ &= \frac{\pi (12)^2}{4} \\ &= 36\pi \end{aligned}$$

$$\begin{aligned} \text{Shaded Area} &= 36\pi - 18\pi \\ &= 18\pi \text{ or } 56.5 \text{ cm}^2 \end{aligned}$$

(Total for question 12 is 3 marks)

13 A circle is enclosed by a square as shown in the diagram.

Each side of the square measures 8cm.

Find the area of the shaded region.

Give your answer correct to 1 decimal place.

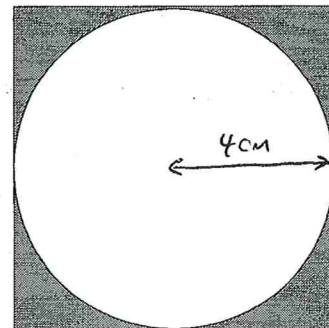

Area of square = $8 \times 8 = 64 \text{ cm}^2$

Area of circle = $\pi (4)^2$
 $= 16\pi$

Shaded Area = $64 - 16\pi$
 $\approx 13.7 \text{ cm}^2$

.....13.7..... cm^2

(Total for question 13 is 3 marks)

14

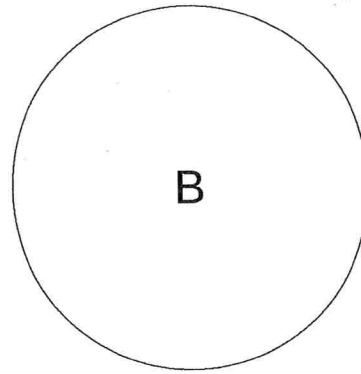
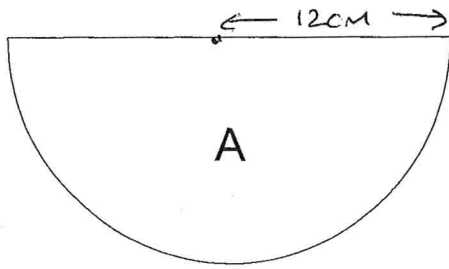

Shape A is a semi-circle which has a radius of 12 cm.

Shape B is a circle.

The area of shape A is 8 times the area of shape B.

Show that the radius of shape B is 3 cm.

$$\begin{aligned}
 \text{Area of semi-circle} &= \frac{\pi r^2}{2} \\
 &= \frac{\pi (12)^2}{2} \\
 &= \underline{\underline{72\pi}}
 \end{aligned}$$

$$\begin{aligned}
 \text{Area of B} &= \frac{72\pi}{8} \\
 &= 9\pi
 \end{aligned}$$

$$\begin{aligned}
 \text{Area of circle} &= \pi r^2 \\
 \pi r^2 &= 9\pi \\
 r^2 &= 9 \\
 r &= \underline{\underline{3}}
 \end{aligned}$$

(Total for question 14 is 3 marks)

1

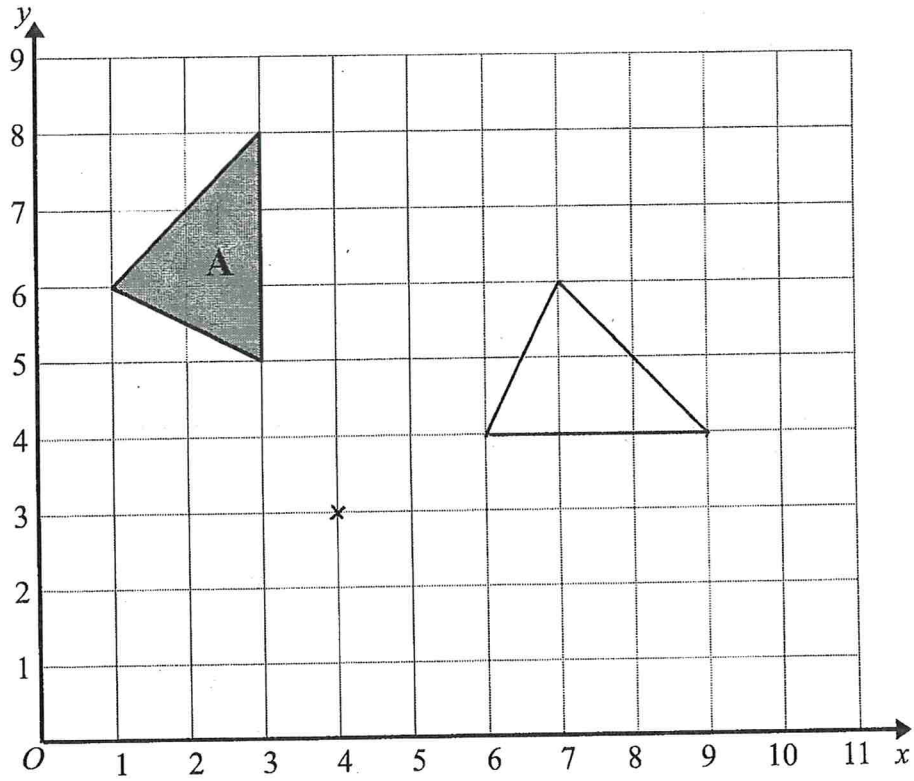

Rotate triangle A 90° clockwise about (4,3).

(Total for question 1 is 2 marks)

2

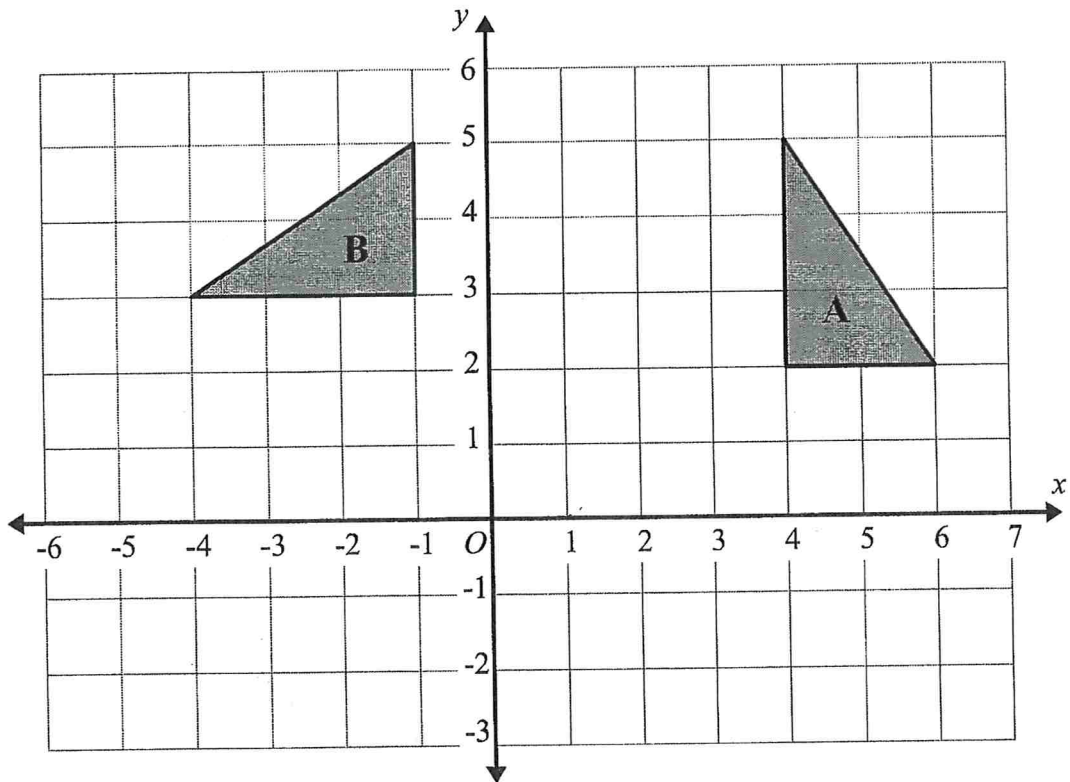

Describe fully the single transformation that maps triangle A on triangle B.

...Rotation, 90° Anti Clockwise, Centre (1, 0).....

(Total for question 2 is 2 marks)

3

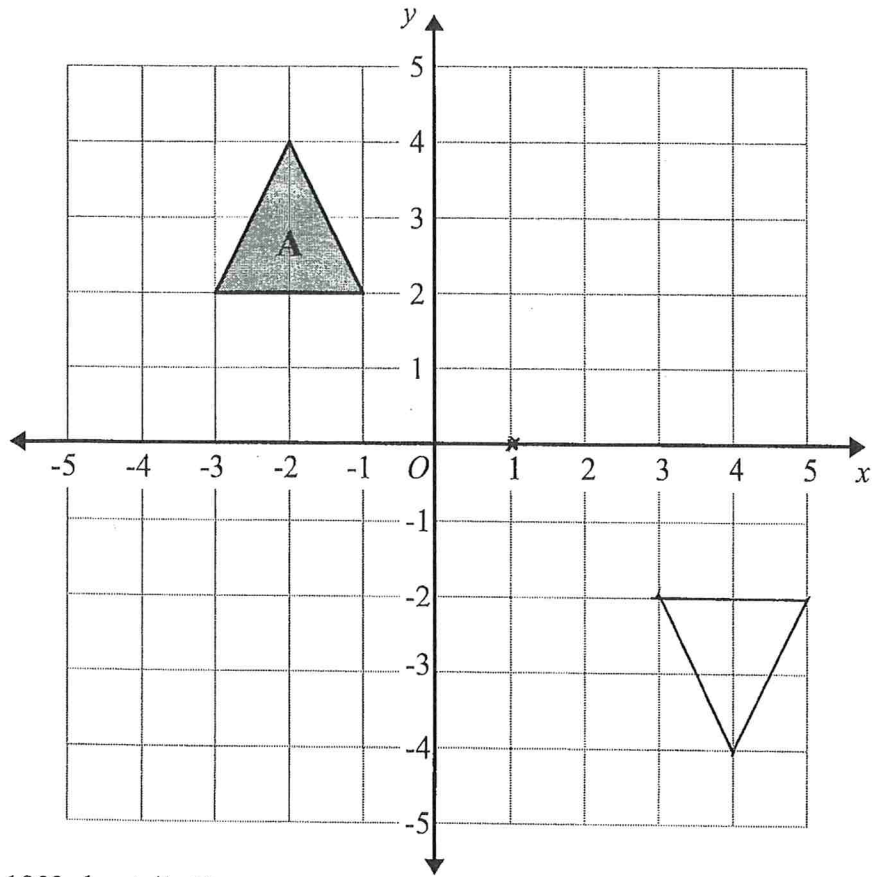

Rotate shape A 180° about $(1, 0)$

(Total for question 3 is 2 marks)

4

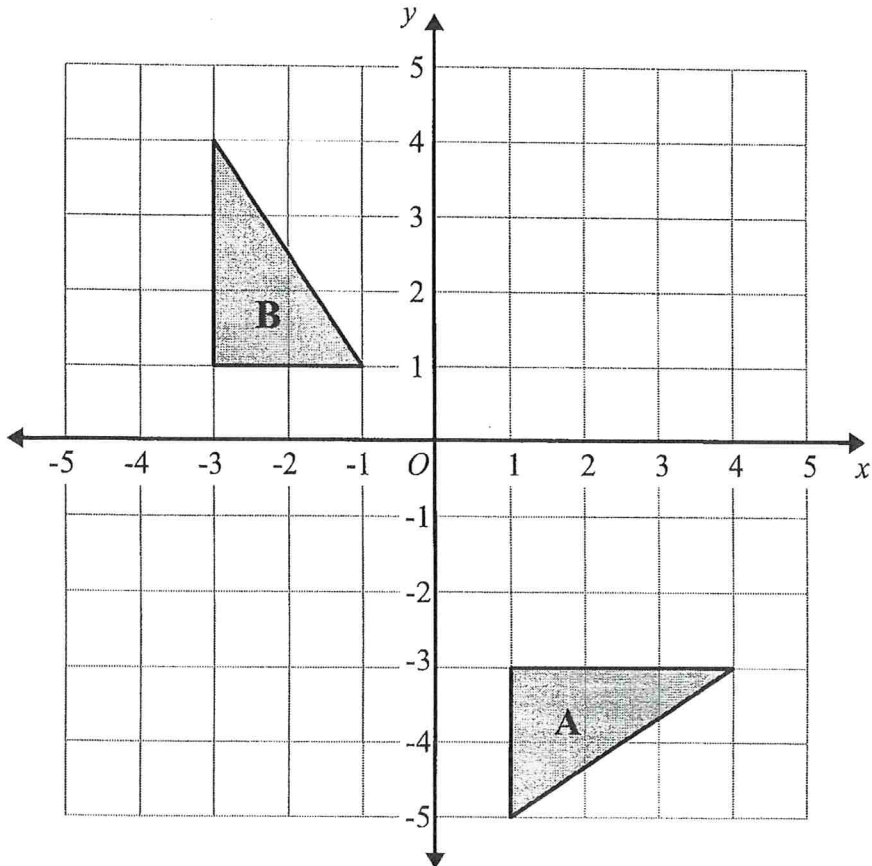

Describe fully the single transformation that maps triangle A on triangle B.

Rotation, 90° Anti Clockwise, (centre $(-3, -3)$)

(Total for question 4 is 2 marks)

5

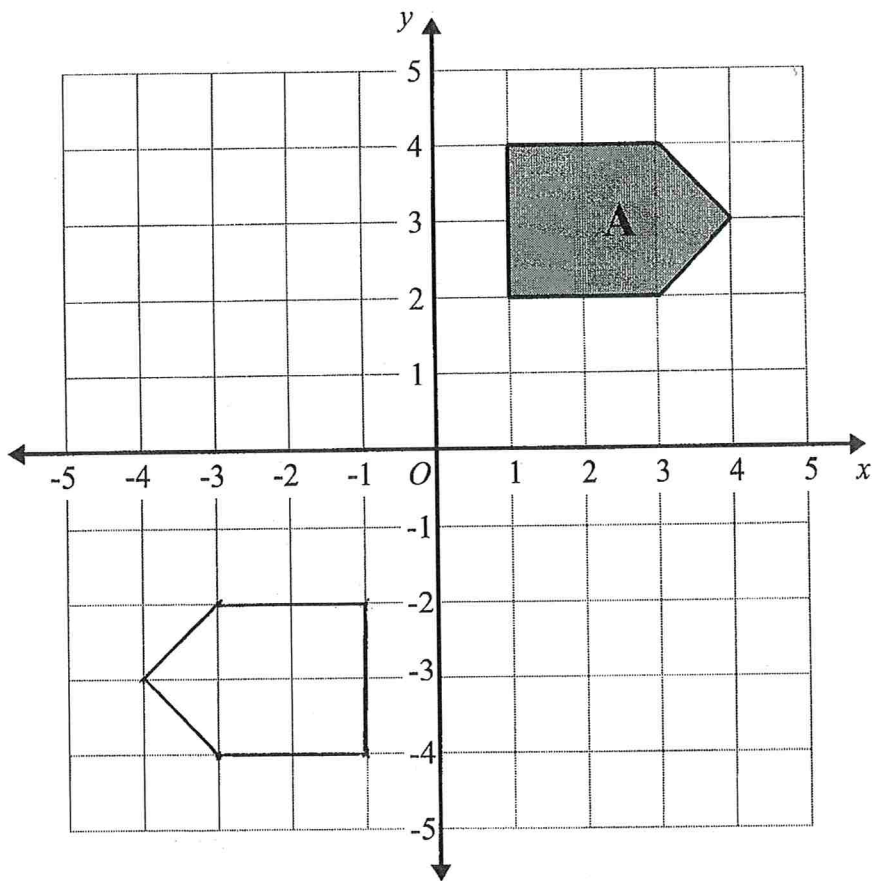

Rotate shape A 180° about O .

(Total for question 5 is 2 marks)

6

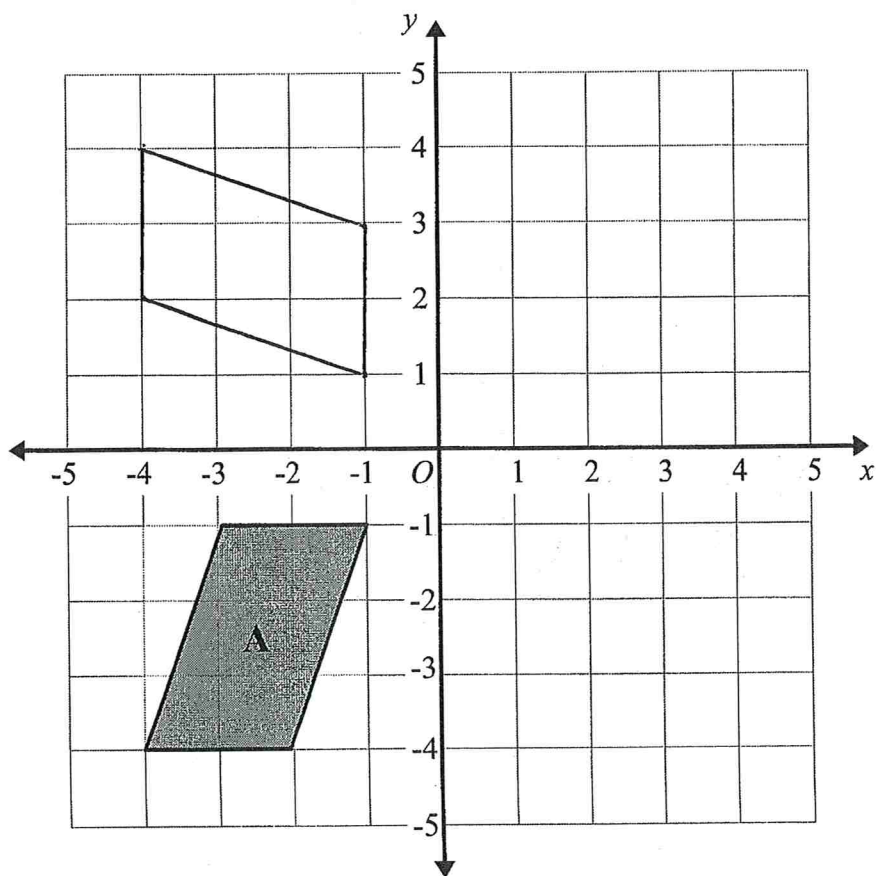

Rotate shape A 90° clockwise about centre O .

(Total for question 6 is 2 marks)

7

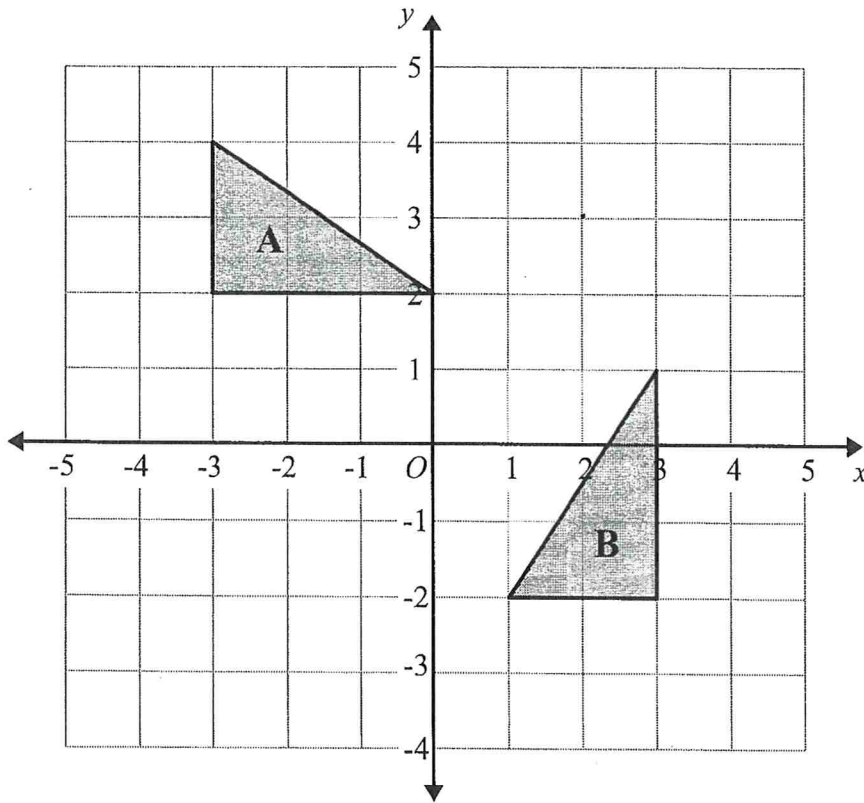

Describe fully the single transformation that maps triangle A on triangle B.

Rotation, 90° Anticlockwise, Centre (2,3)

(Total for question 7 is 2 marks)

8

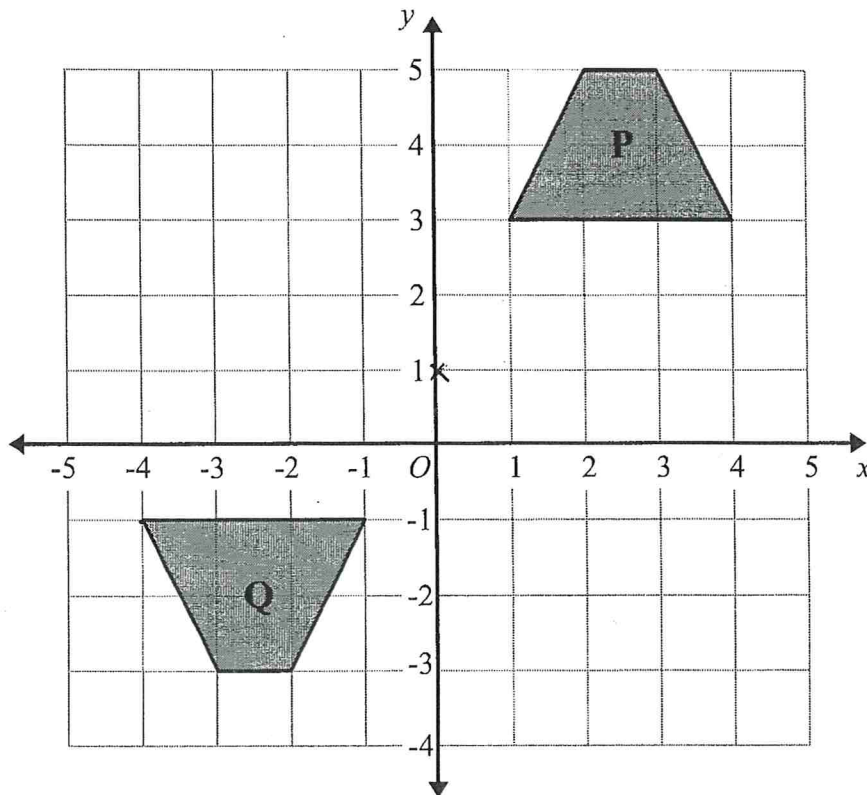

Describe fully the single transformation that maps triangle P on triangle Q.

Rotation, 180°, centre (0,1)

(Total for question 8 is 2 marks)

1 On the grid, reflect the shaded shape in the mirror line.

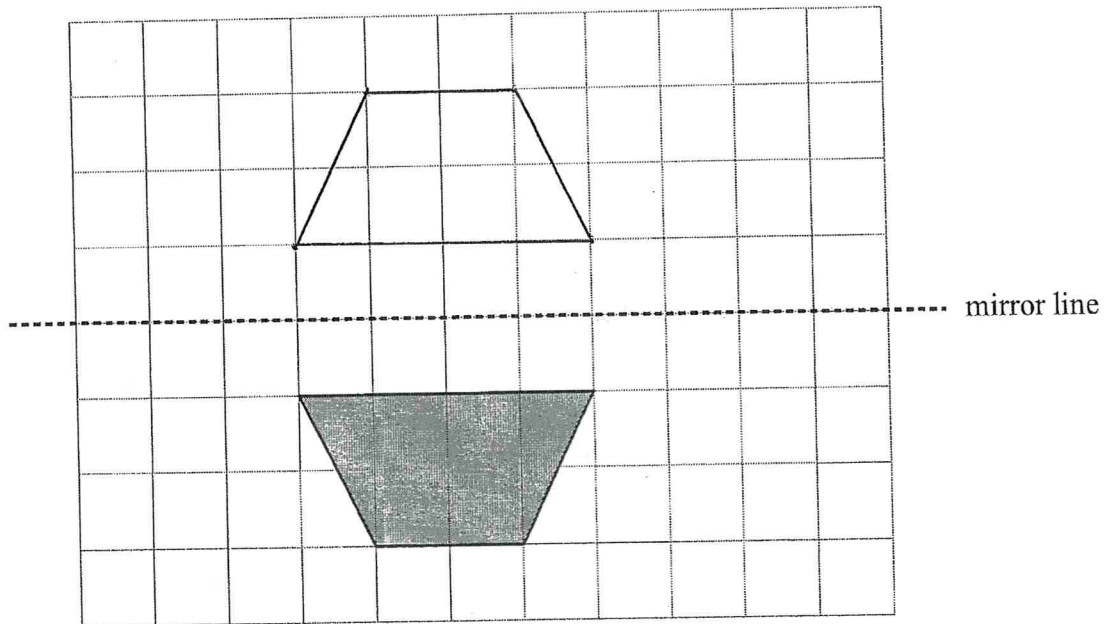

(Total for question 1 is 1 mark)

2

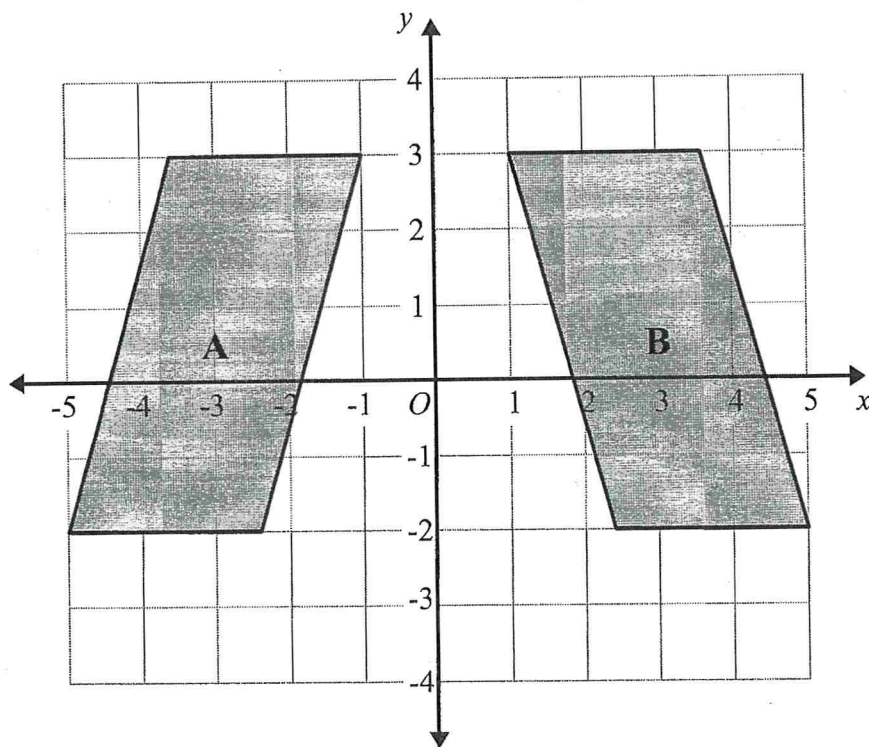

Describe fully the single transformation that maps shape A onto shape B.

..... reflection in the y-axis

.....

(Total for question 2 is 2 marks)

3

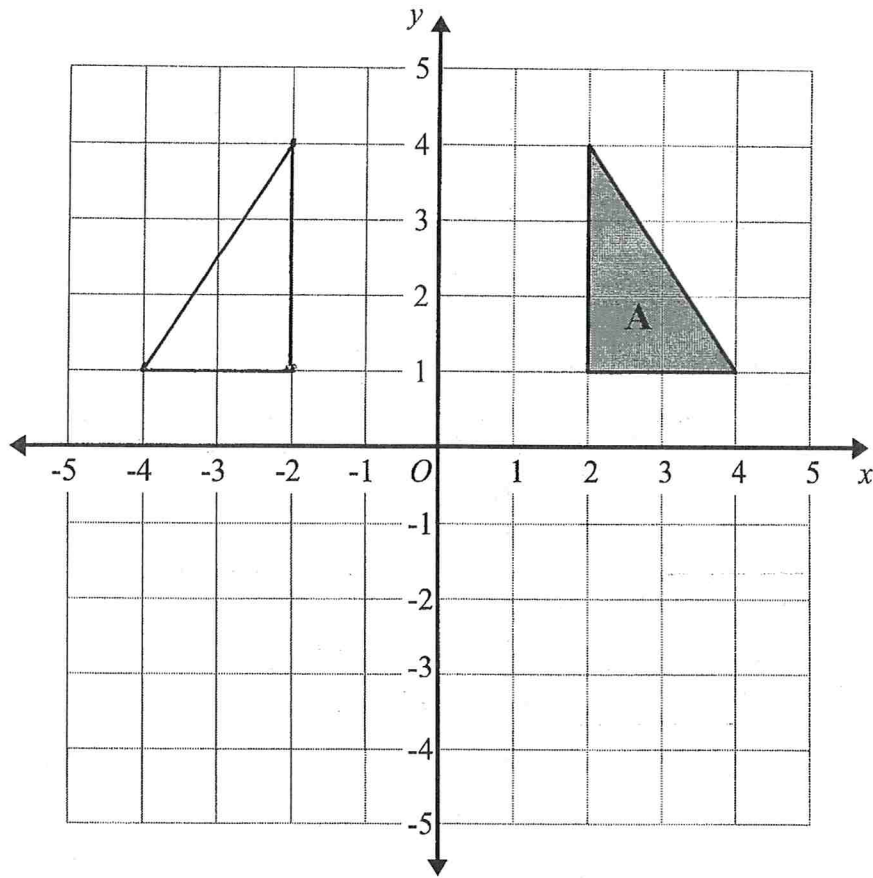

Reflect triangle A in the y -axis.

(Total for question 3 is 2 marks)

4

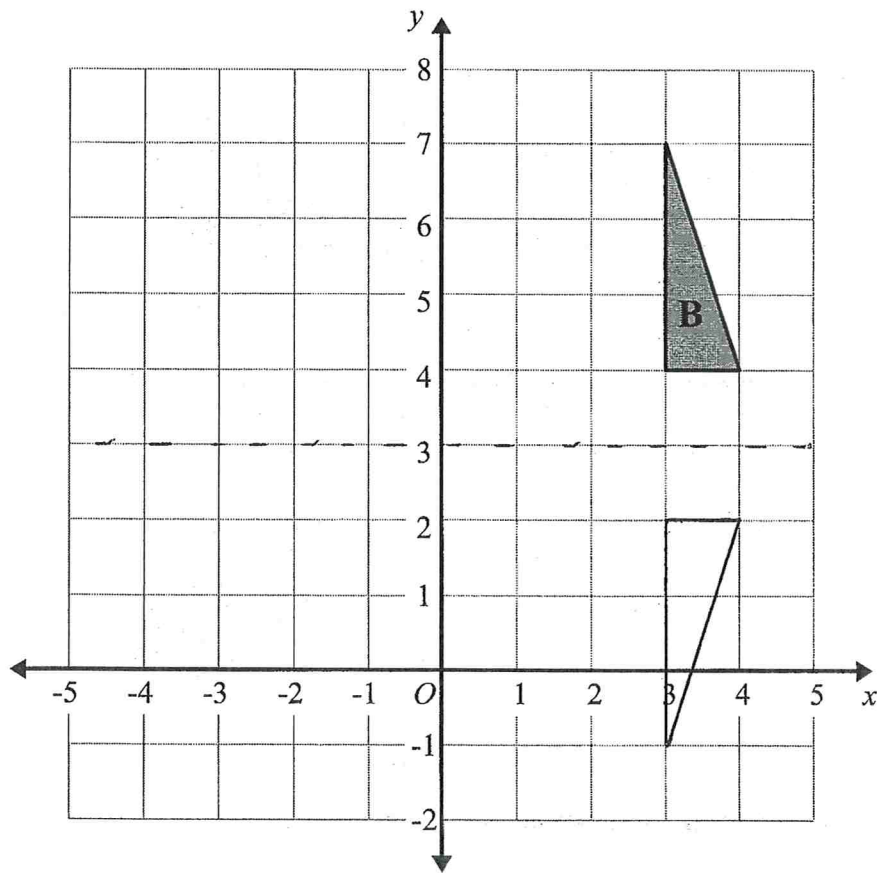

Reflect shape **B** in the line $y = 3$.

(Total for question 4 is 2 marks)

5

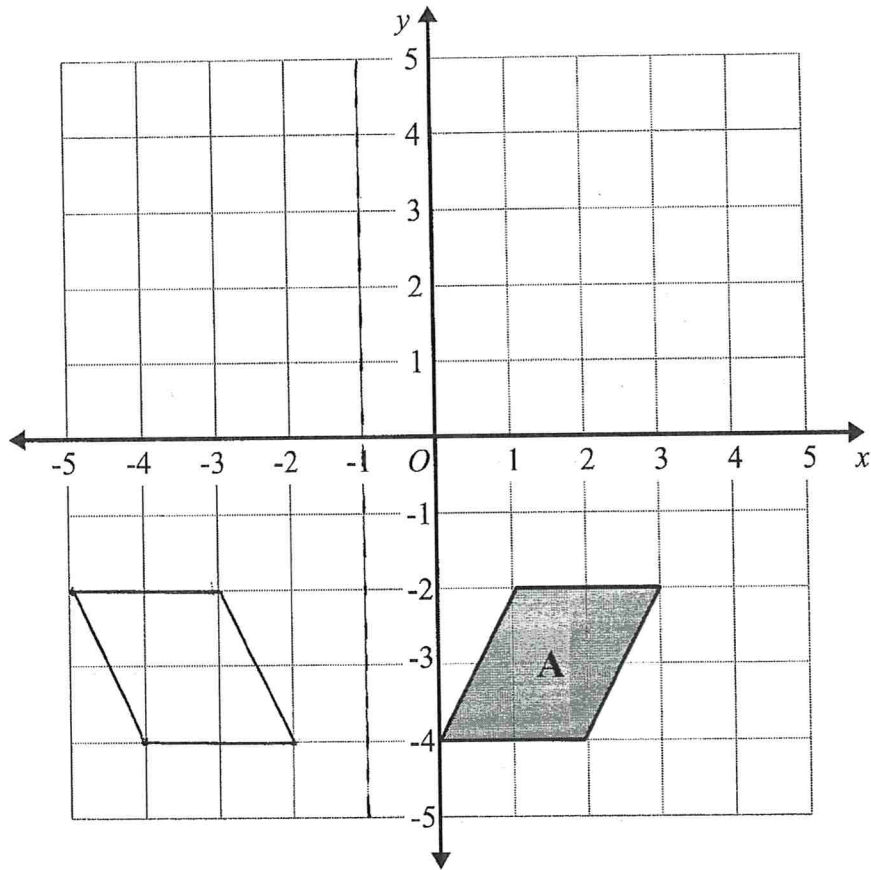

Reflect shape A in the line with equation $x = -1$

(Total for question 5 is 2 marks)

6

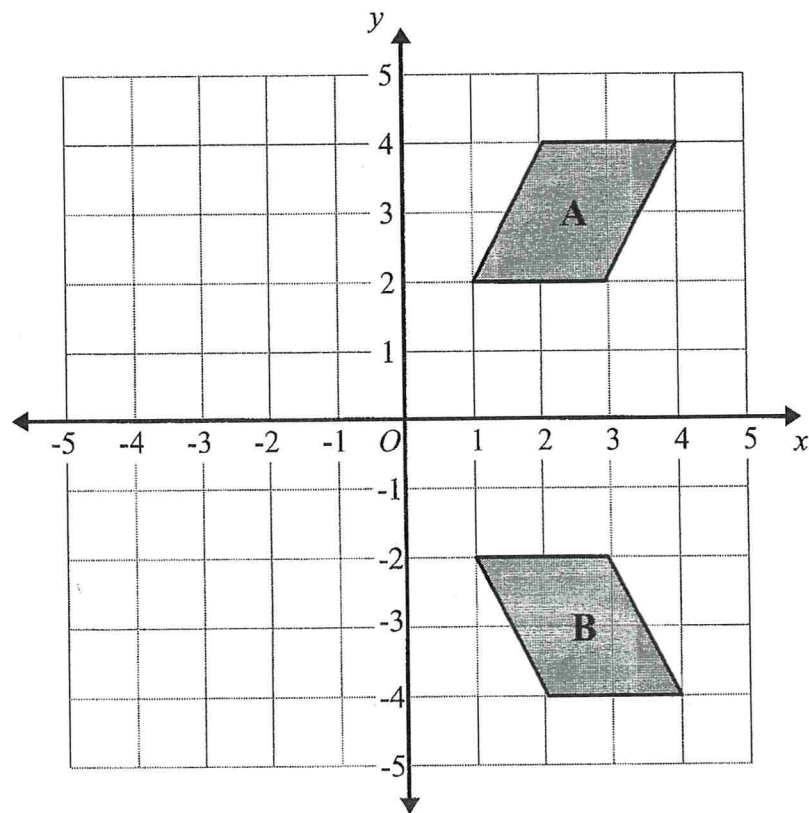

Describe fully the single transformation that maps shape A onto shape B.

..... *reflection in the x-axis*

(Total for question 6 is 2 marks)

7

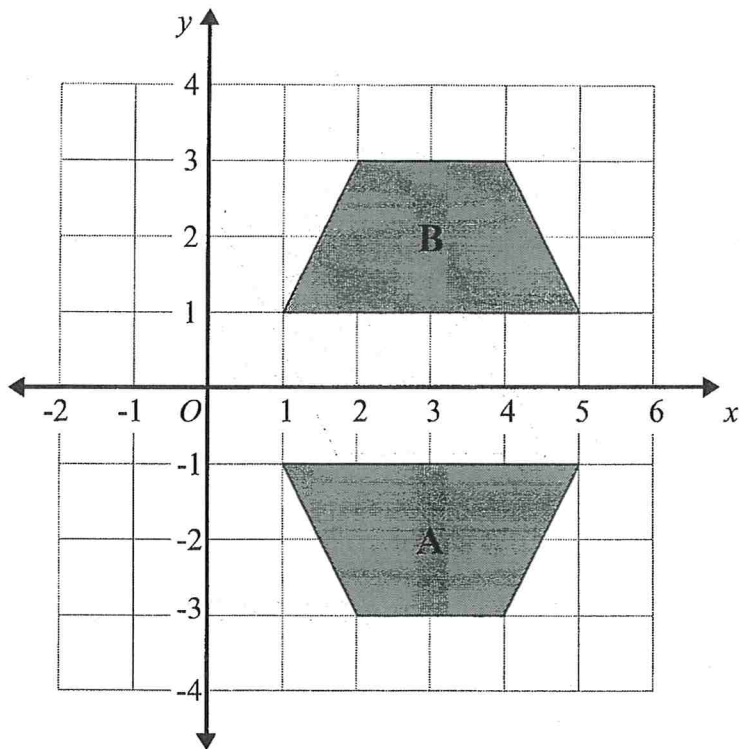

Describe fully the single transformation that maps shape A onto shape B.

Reflection in the x-axis

(Total for question 7 is 2 marks)

8

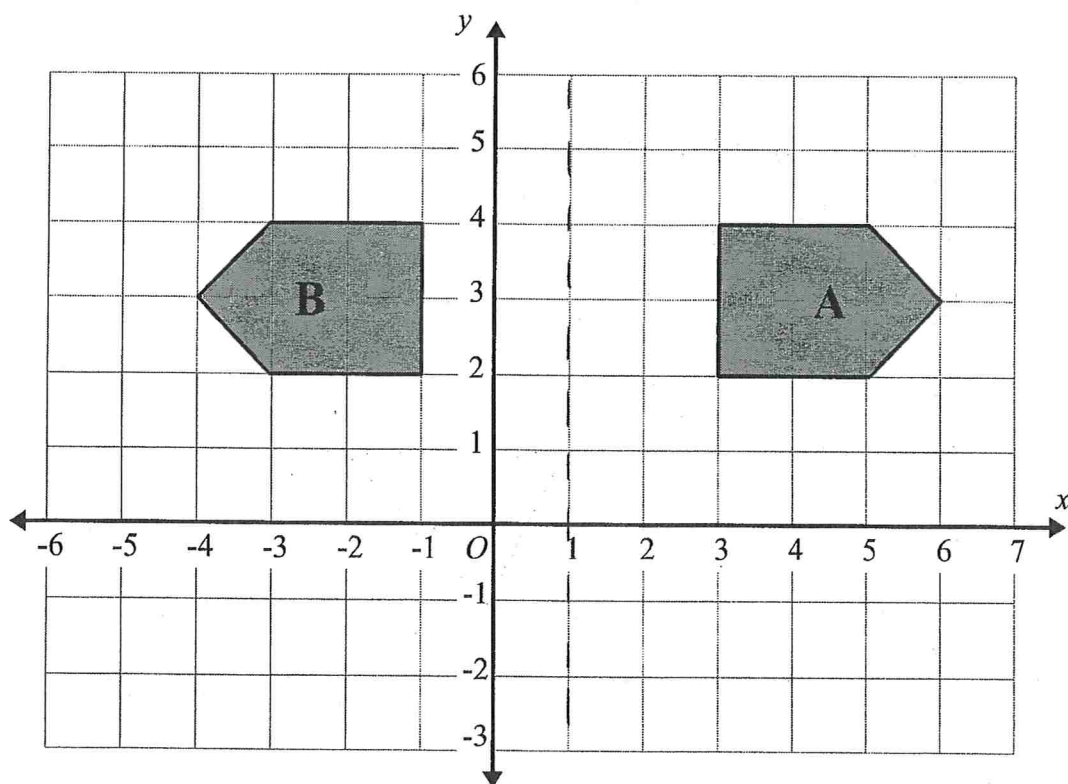

Describe fully the single transformation that maps shape A onto shape B.

Reflection in the line $x=1$

(Total for question 8 is 2 marks)

9

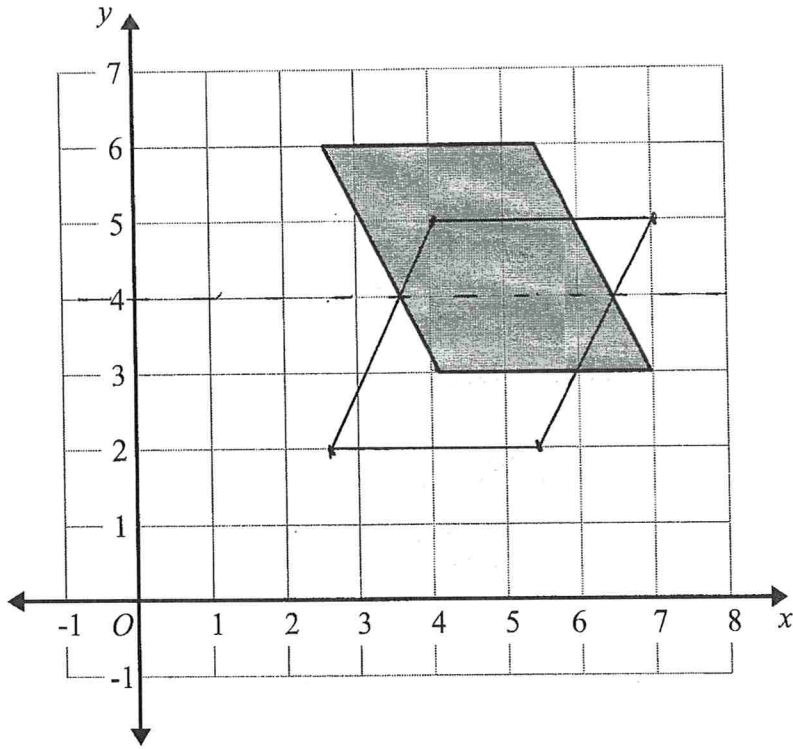

Reflect the shaded shape in the line $y = 4$

(Total for question 9 is 2 marks)

10

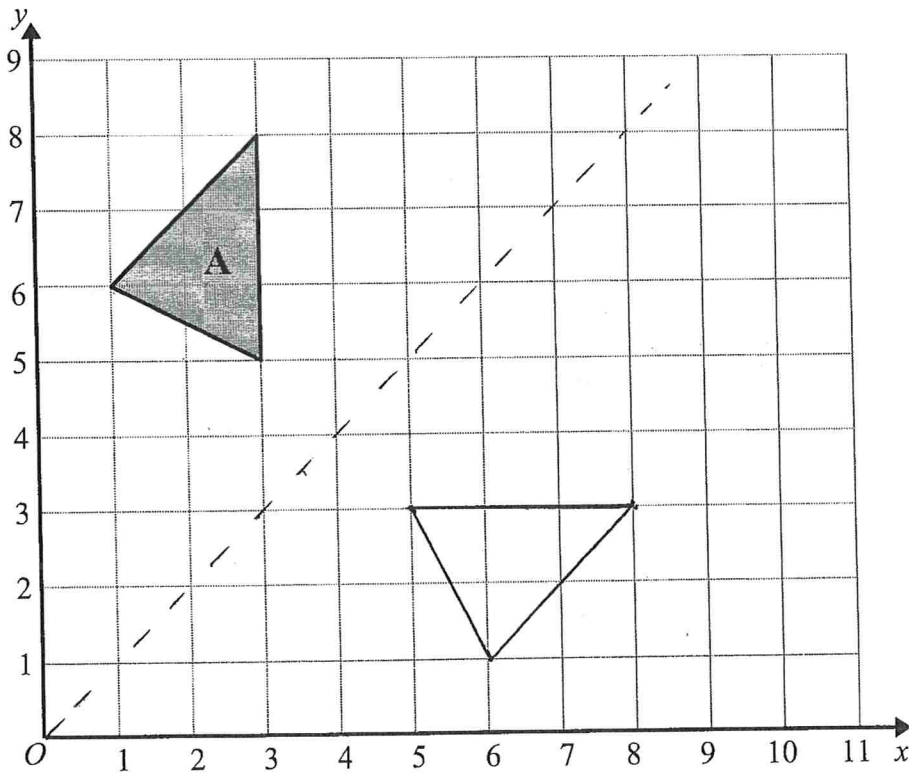

Reflect triangle A in the line $y = x$

(Total for question 10 is 2 marks)

1

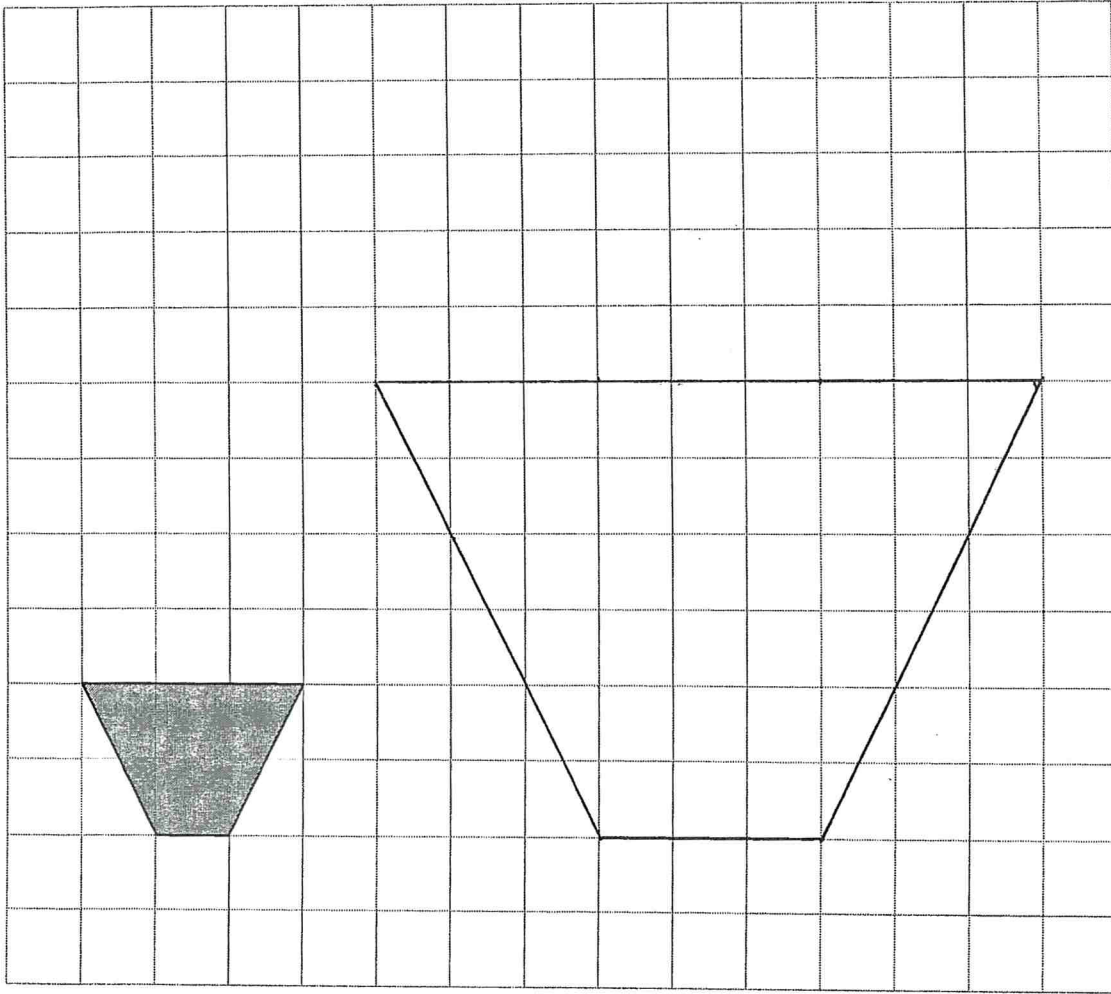

On the grid draw an enlargement of the shaded shape with scale factor 3

(Total for question 1 is 2 marks)

2

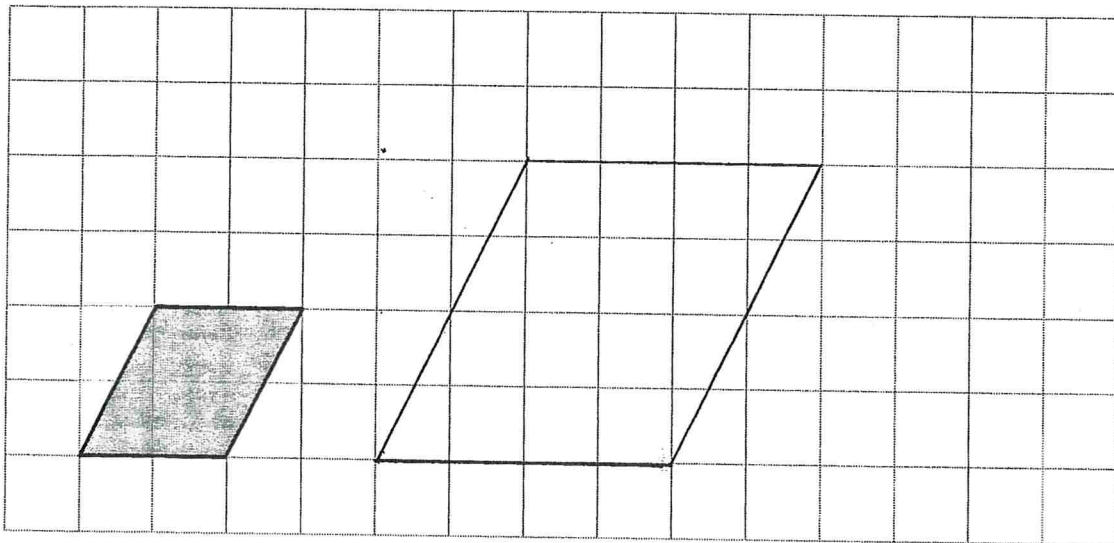

On the grid draw an enlargement of the shaded shape with scale factor 2

(Total for question 2 is 2 marks)

3

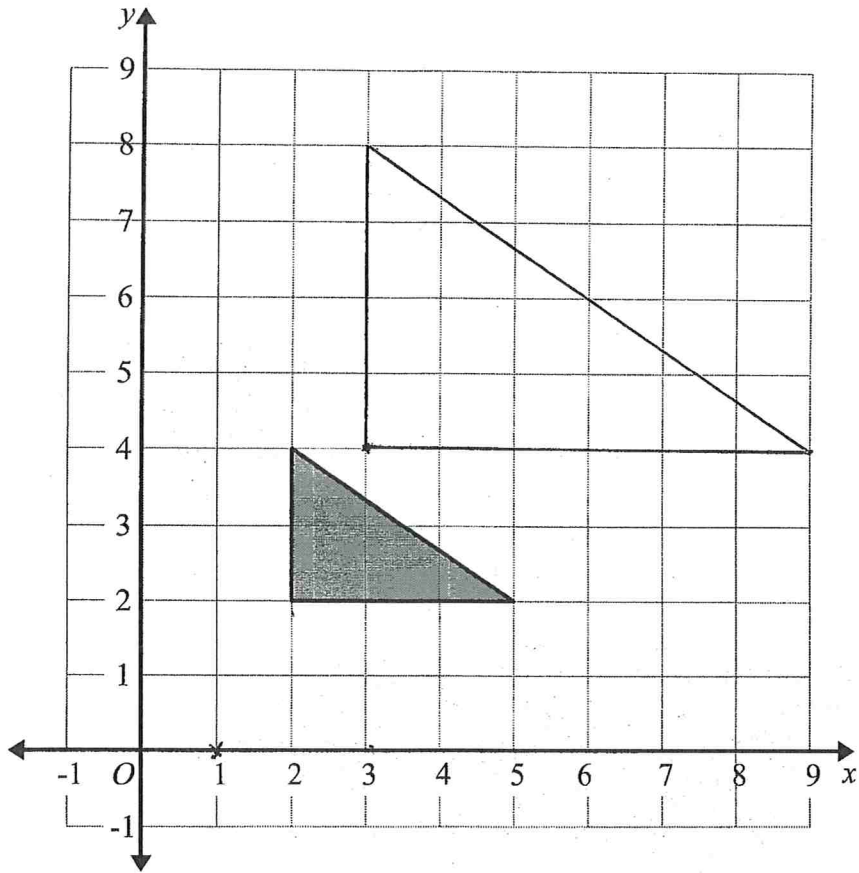

Enlarge the shaded triangle by scale factor 2, centre $(1, 0)$

(Total for question 3 is 2 marks)

4

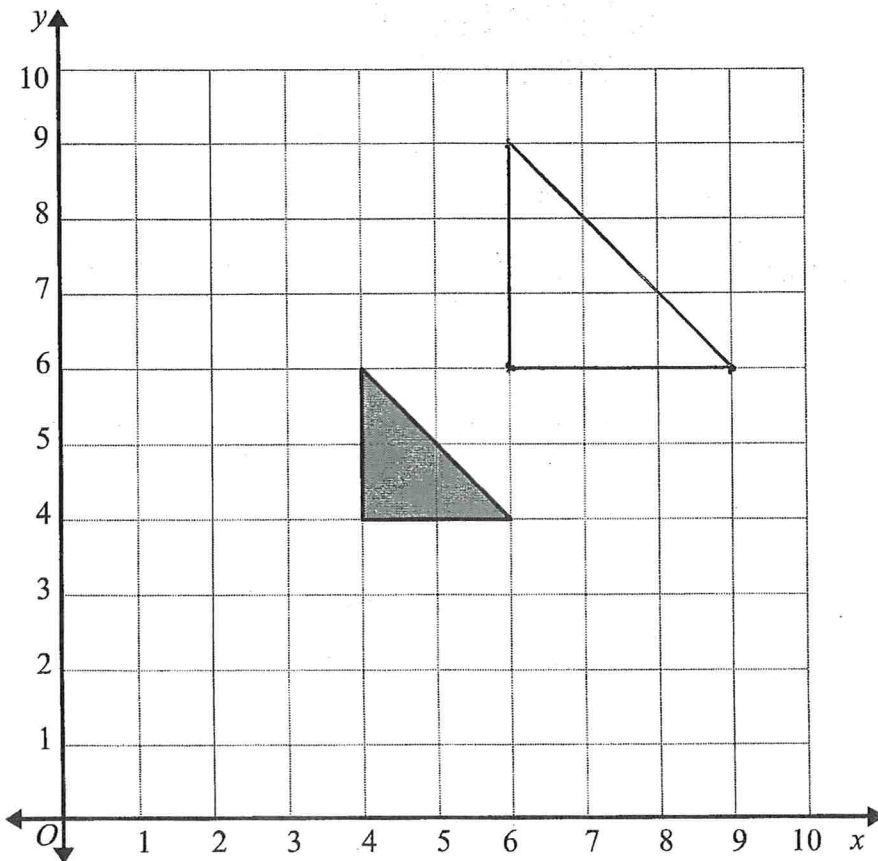

Enlarge the shaded triangle by scale factor 1.5, centre O .

(Total for question 4 is 2 marks)

5

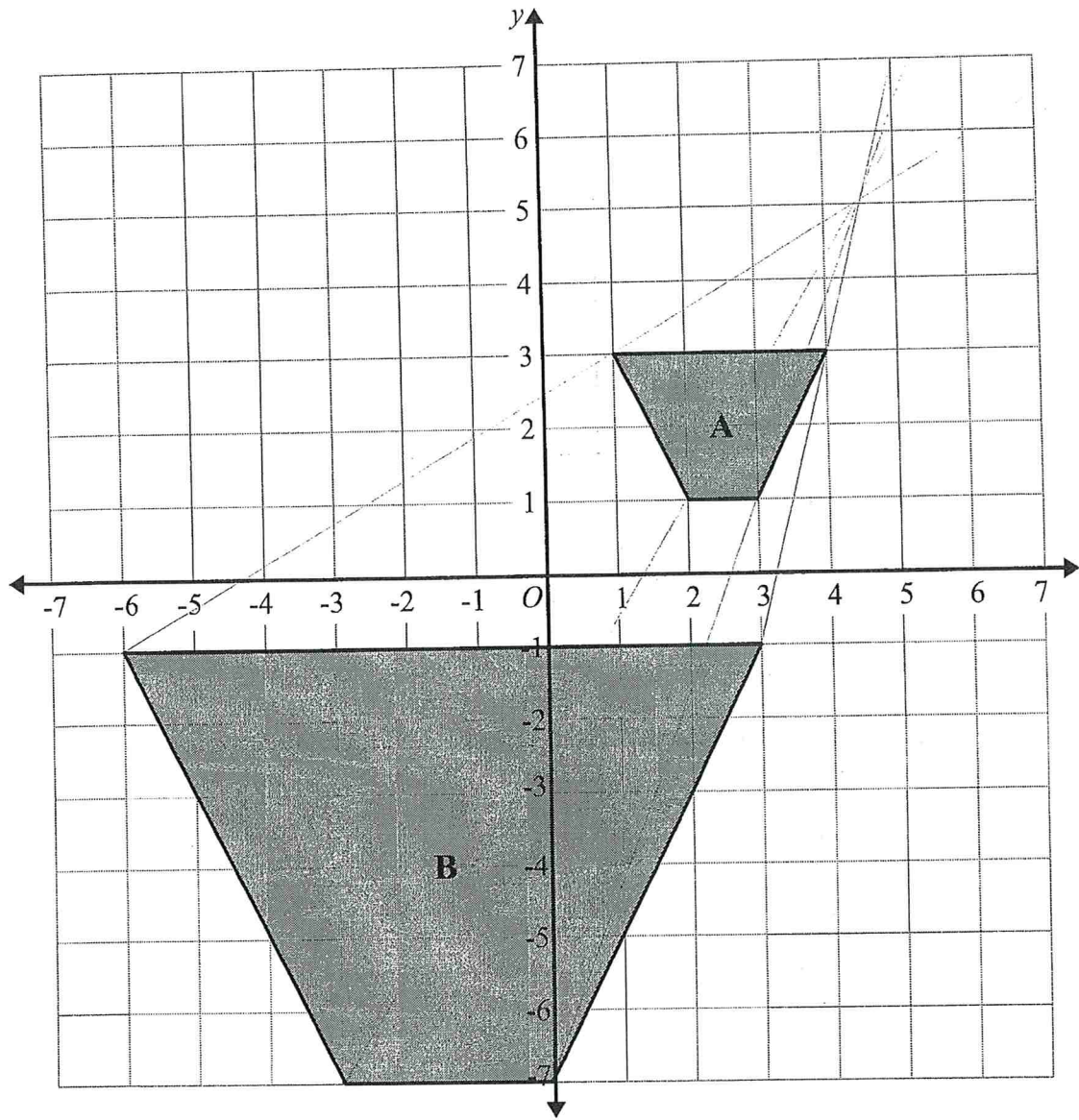

Describe fully the single transformation that maps shape A onto shape B.

..... Enlargement, Scale factor 3, centre (4.5, 5).....

(Total for question 5 is 2 marks)

6

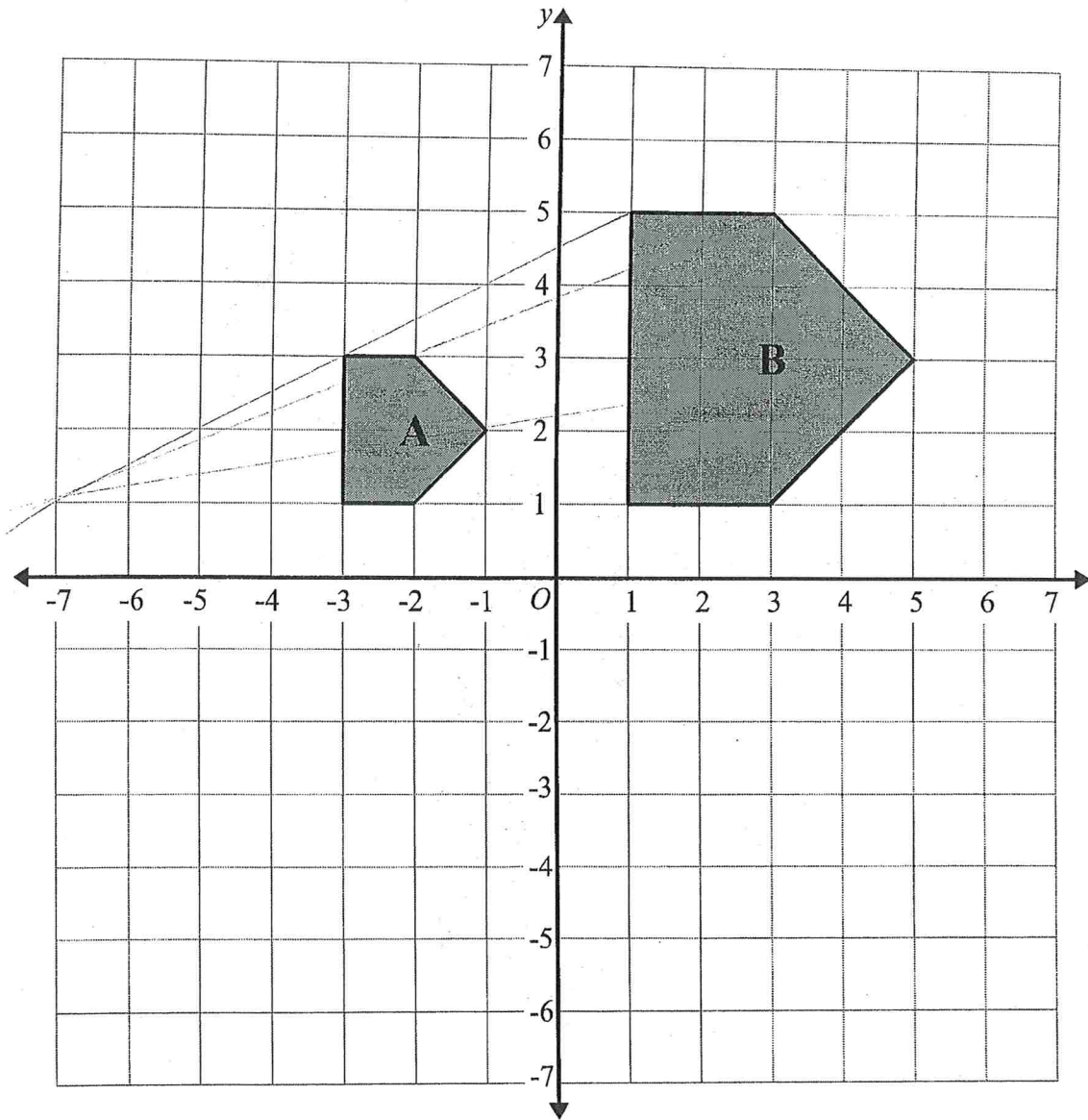

Describe fully the single transformation that maps shape A onto shape B.

..... Enlargement, scale factor 2, centre (-7, 1)

.....

(Total for question 6 is 2 marks)

7

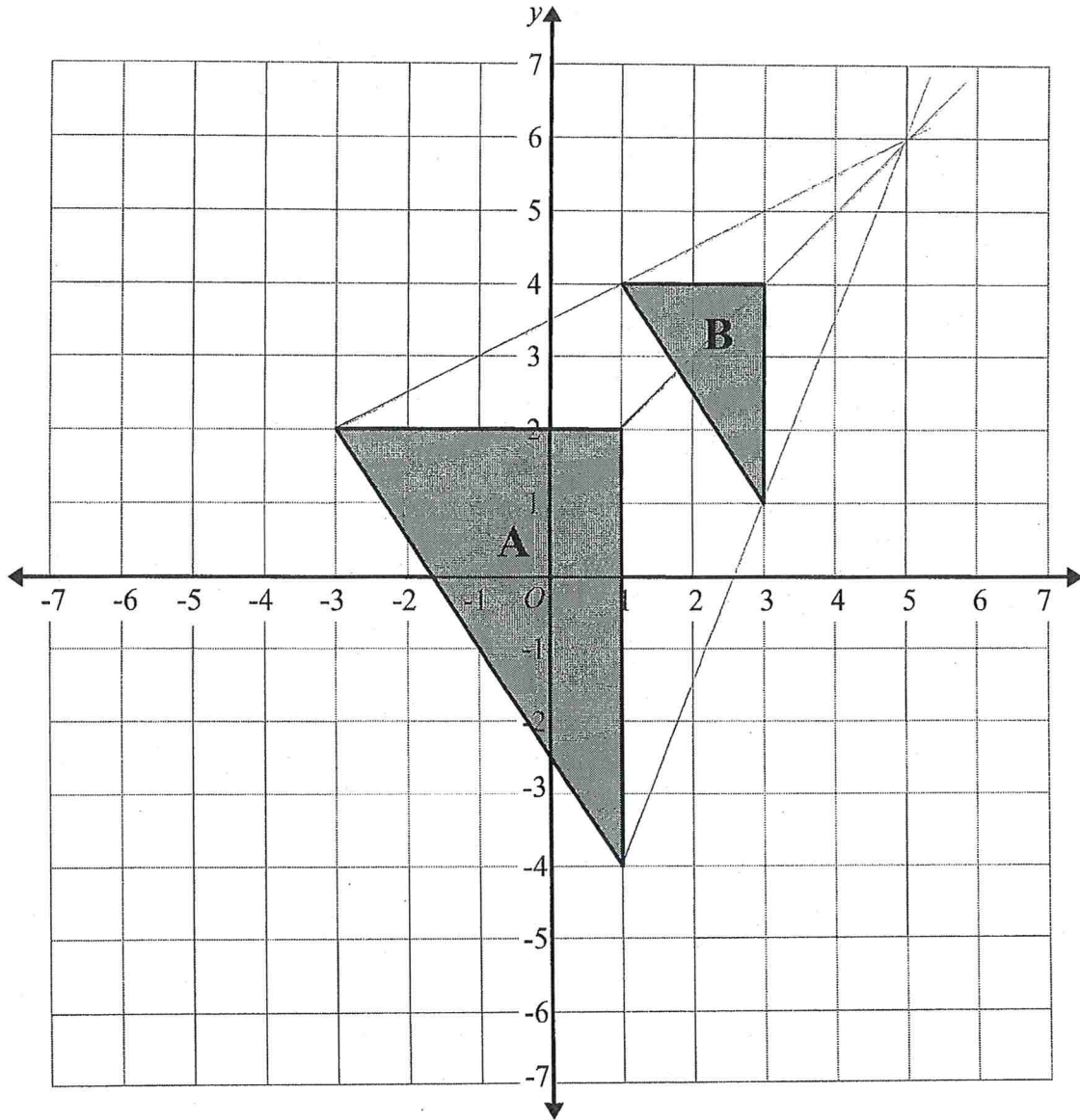

Describe fully the single transformation that maps triangle A on triangle B.

.....Enlargement, scale factor $\frac{1}{2}$, centre (5, 6).....

.....

(Total for question 7 is 2 marks)

1

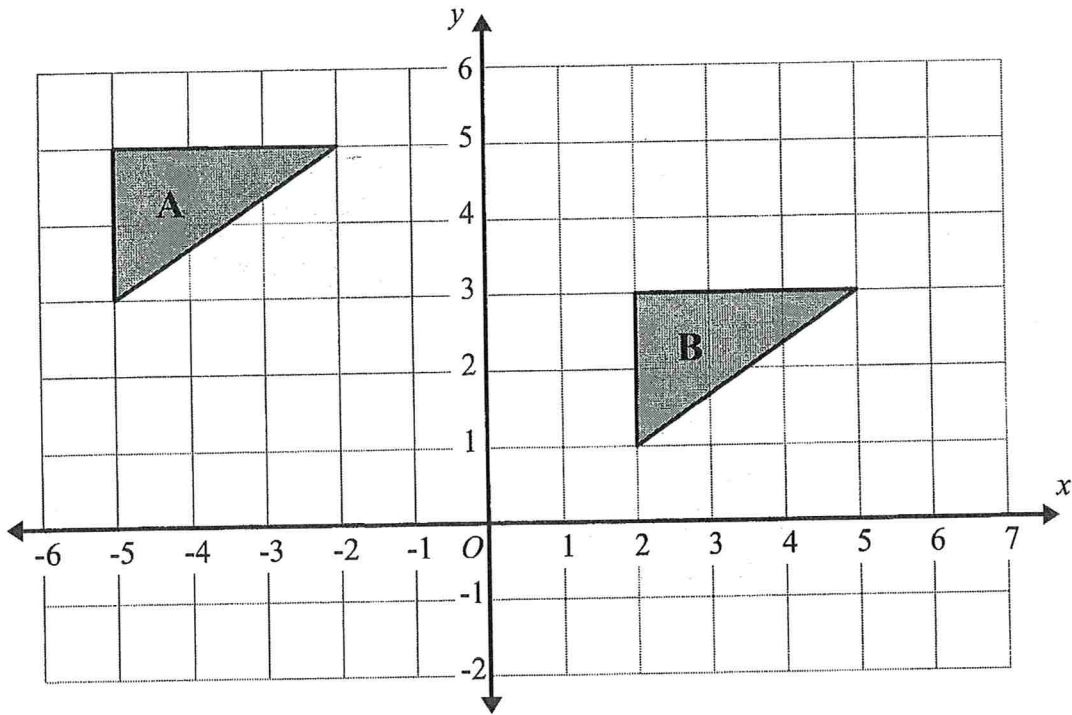

Describe fully the single transformation that maps triangle A on triangle B.

.....translation..... by the vector $\begin{pmatrix} 7 \\ -2 \end{pmatrix}$

(Total for question 1 is 2 marks)

2

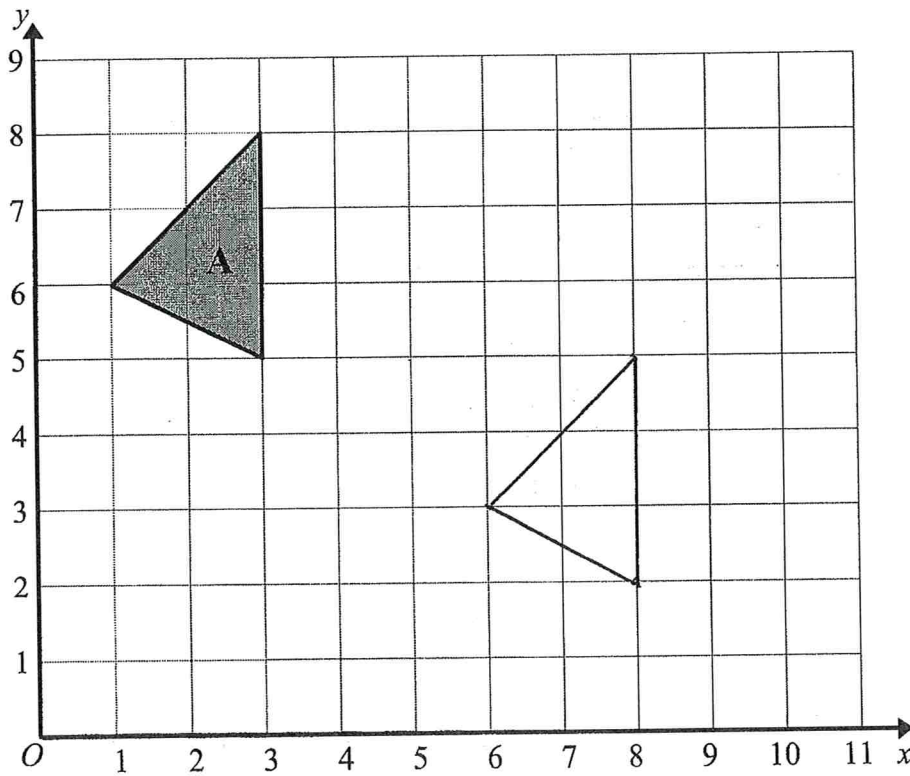

Translate triangle A by the vector $\begin{pmatrix} 5 \\ -3 \end{pmatrix}$

(Total for question 2 is 2 marks)

3

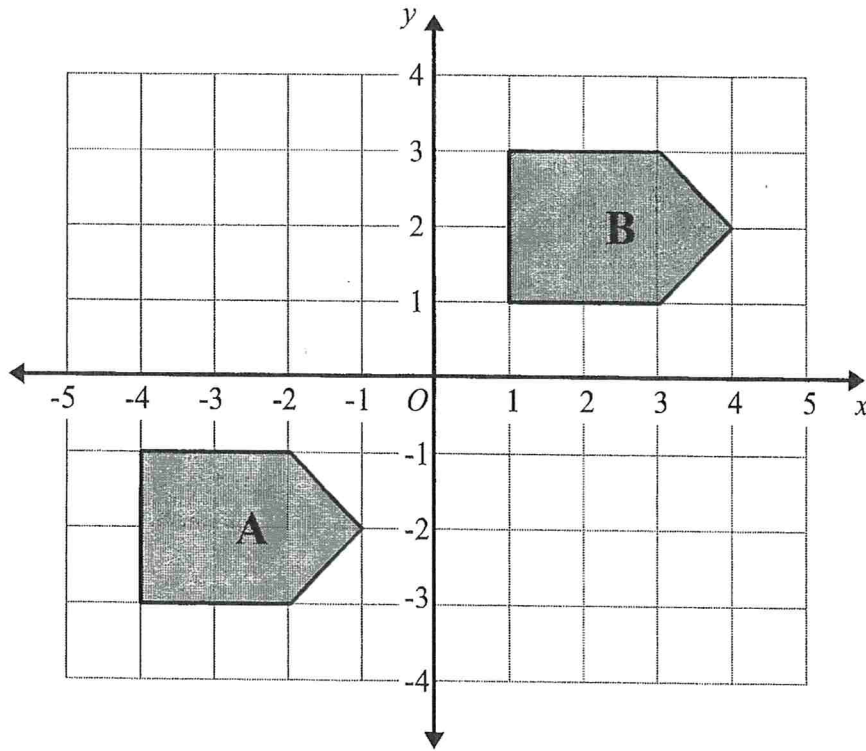

Describe fully the single transformation that maps shape A onto shape B.

translation by the vector $\begin{pmatrix} 5 \\ 4 \end{pmatrix}$

(Total for question 3 is 2 marks)

4

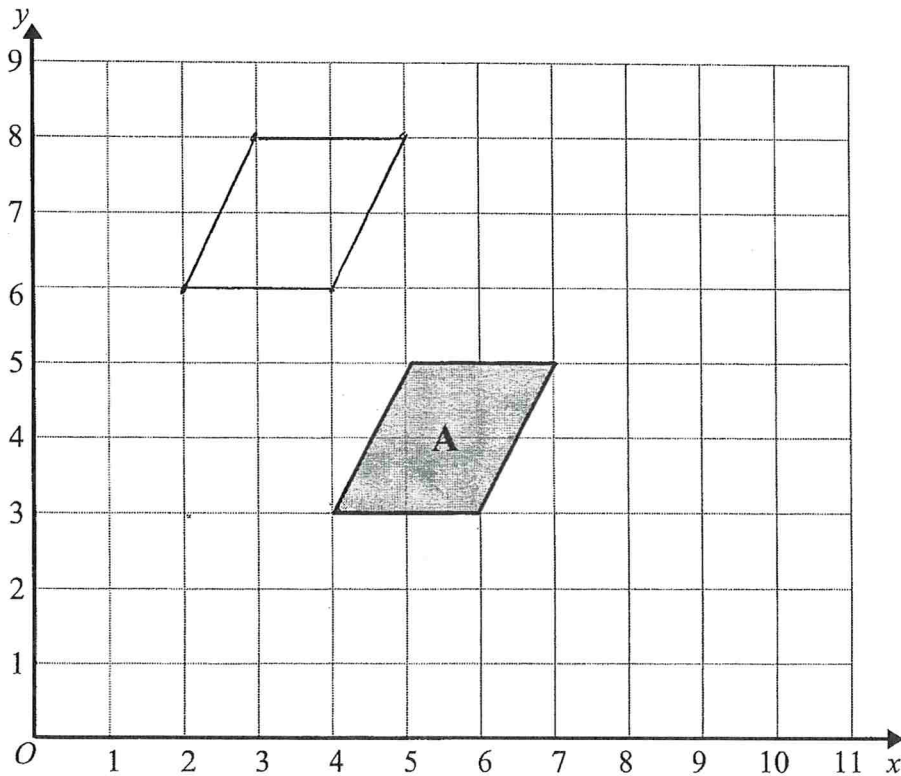

Translate shape A by the vector $\begin{pmatrix} -2 \\ 3 \end{pmatrix}$

(Total for question 4 is 2 marks)

5

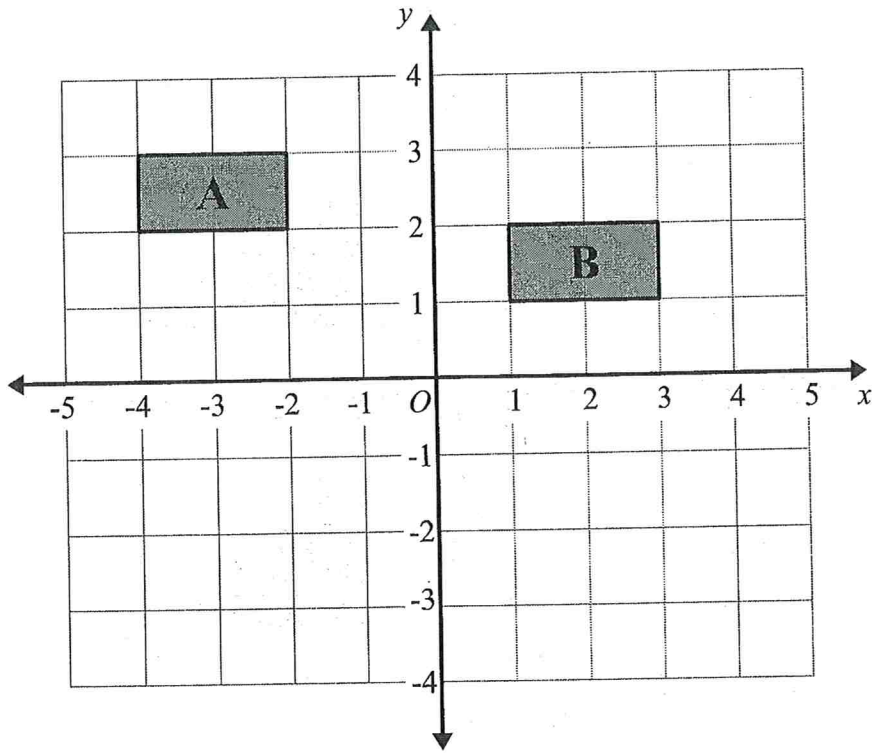

Describe fully the single transformation that maps shape A onto shape B.

..... translation $\begin{pmatrix} 5 \\ -1 \end{pmatrix}$
 by the vector

(Total for question 5 is 2 marks)

6

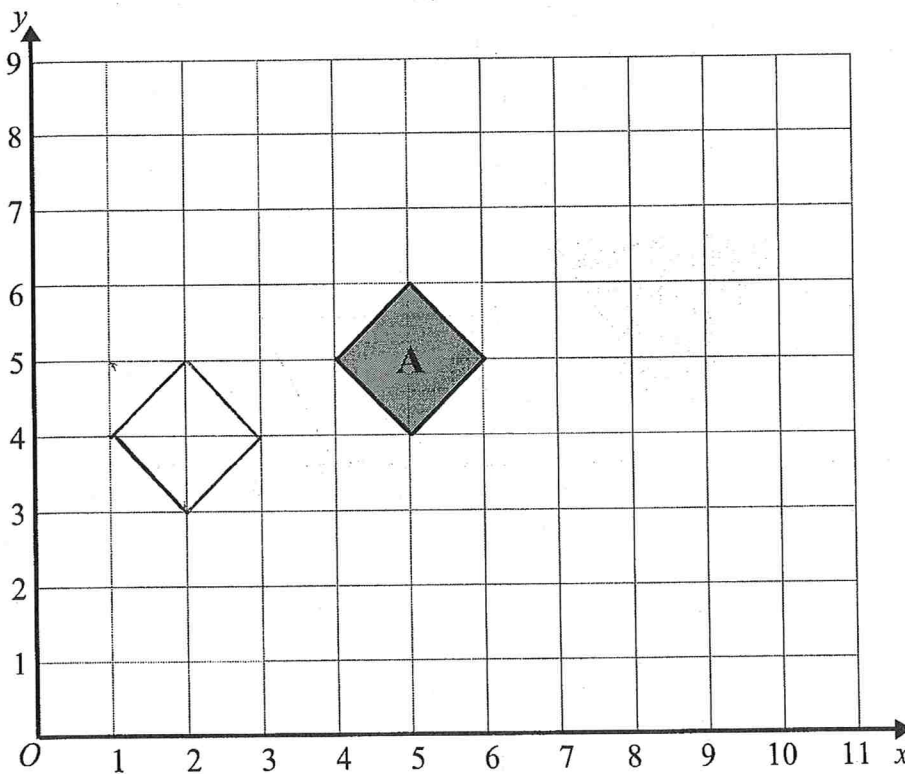

Translate shape A by the vector $\begin{pmatrix} -3 \\ -1 \end{pmatrix}$

(Total for question 6 is 2 marks)

7

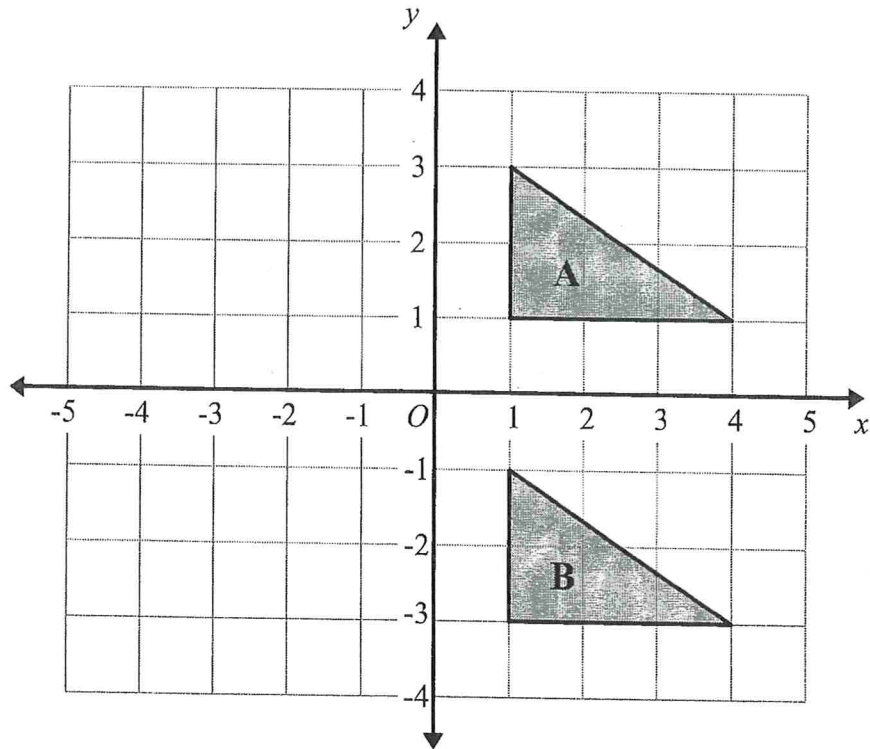

Describe fully the single transformation that maps triangle A on triangle B.

translation $\begin{pmatrix} 0 \\ -4 \end{pmatrix}$
by the vector

(Total for question 7 is 2 marks)

8

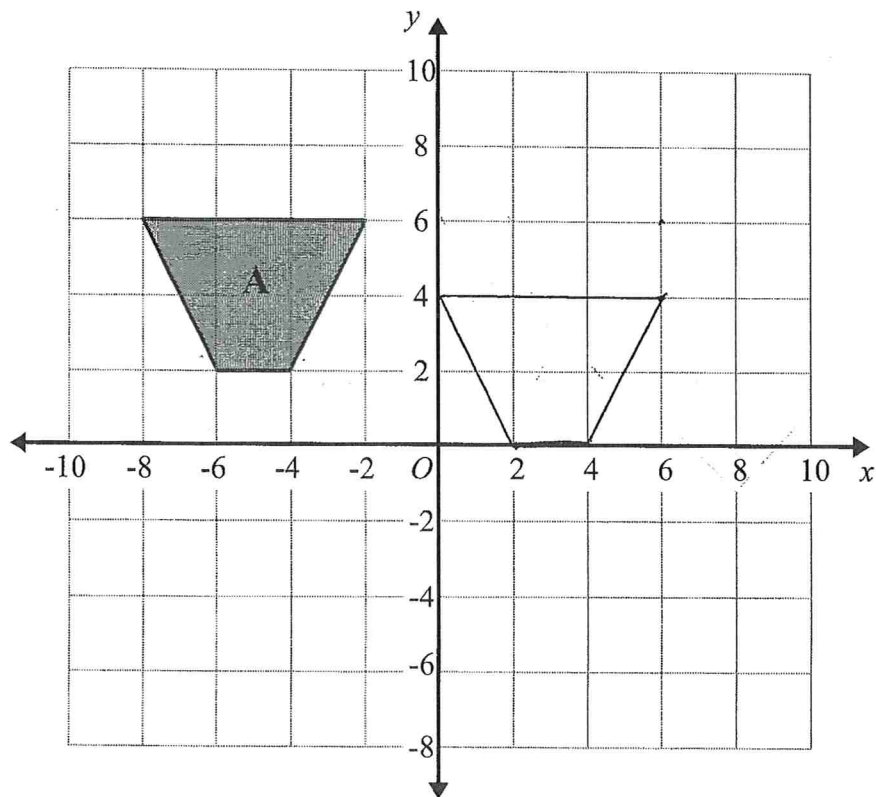

Translate shape A by the vector $\begin{pmatrix} 8 \\ -2 \end{pmatrix}$

(Total for question 8 is 2 marks)

1

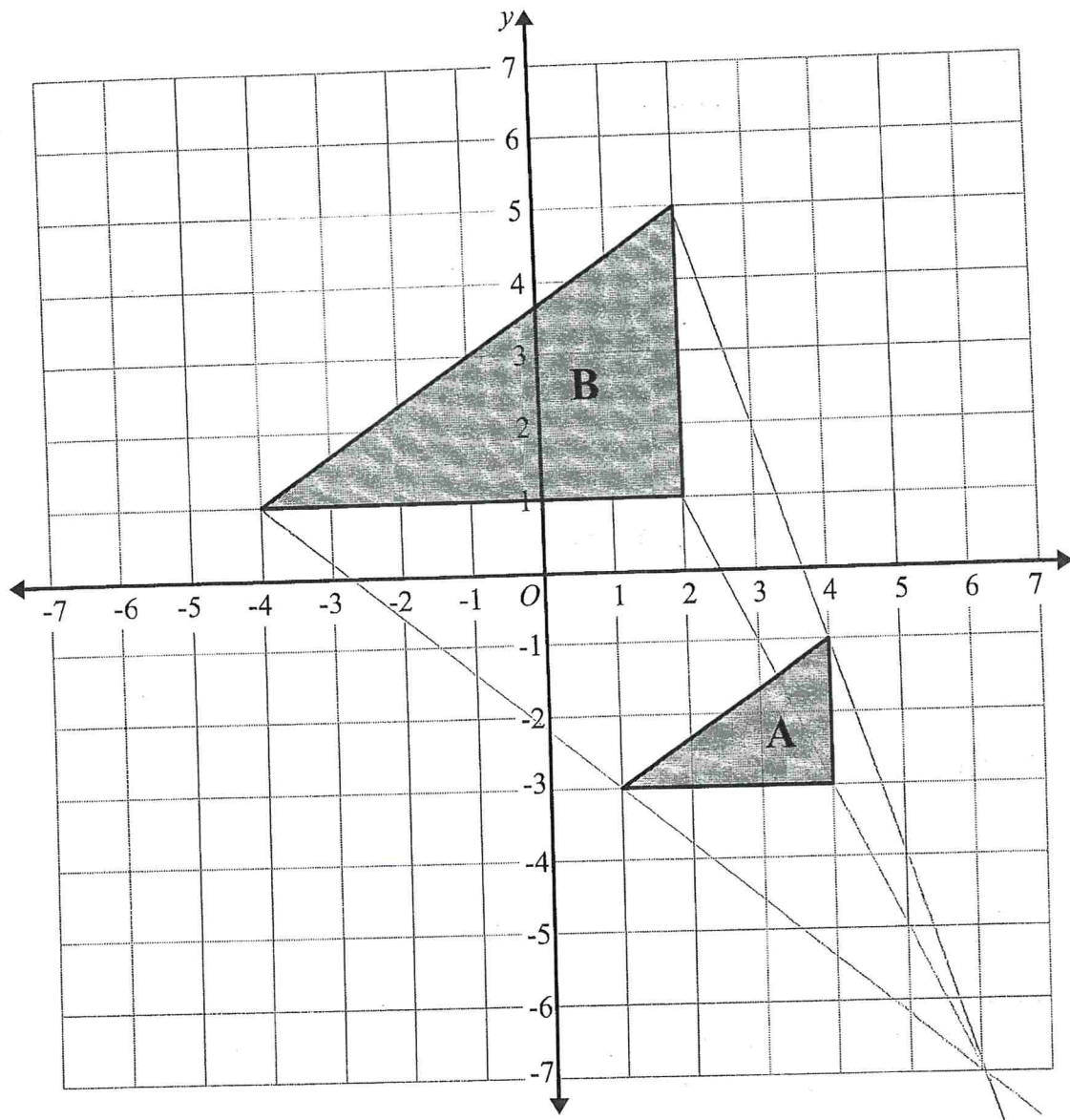

Describe fully the single transformation that maps triangle A on triangle B.

..... Enlargement, Scale Factor 2, Centre (6, -7)

(Total for question 1 is 2 marks)

2

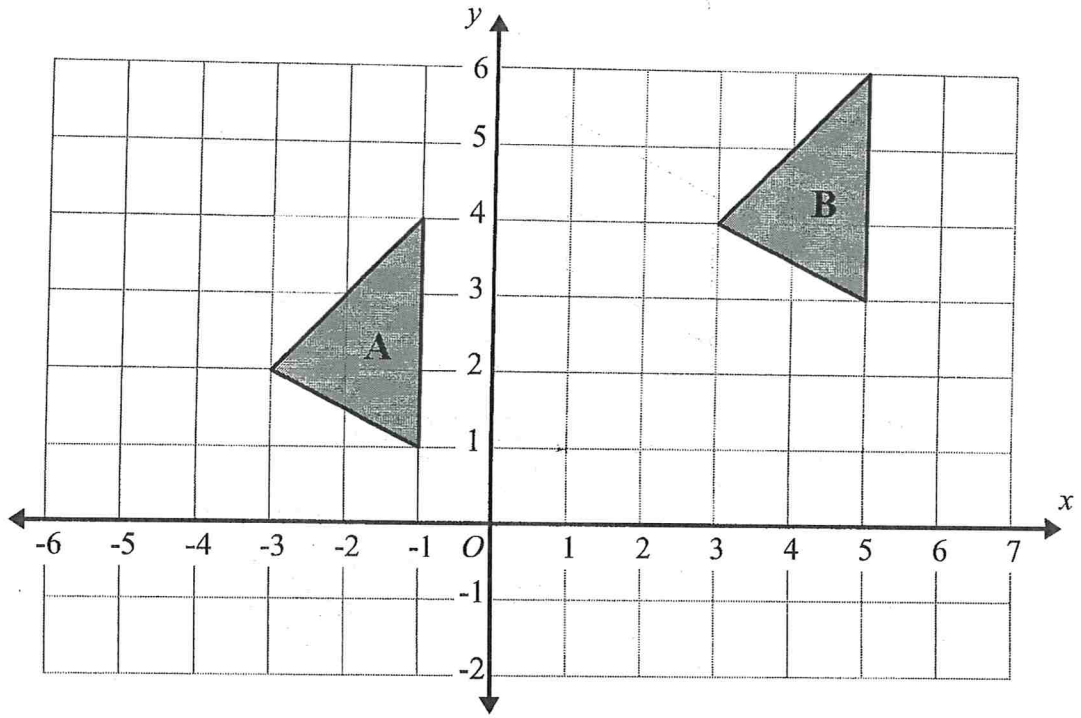

Describe fully the single transformation that maps triangle A on triangle B.

..... translation by the vector $\begin{pmatrix} 6 \\ 2 \end{pmatrix}$

(Total for question 2 is 2 marks)

3

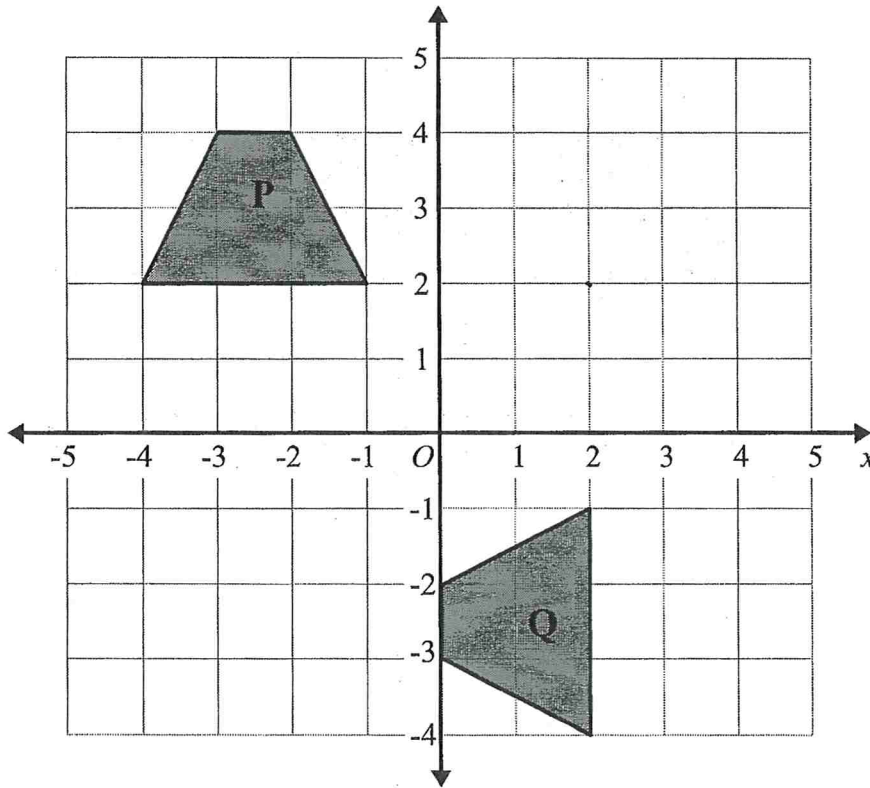

Describe fully the single transformation that maps trapezium P on trapezium Q.

..... Rotation,..... 90° Anti Clockwise,..... Centre $(2, 2)$

(Total for question 3 is 2 marks)

4

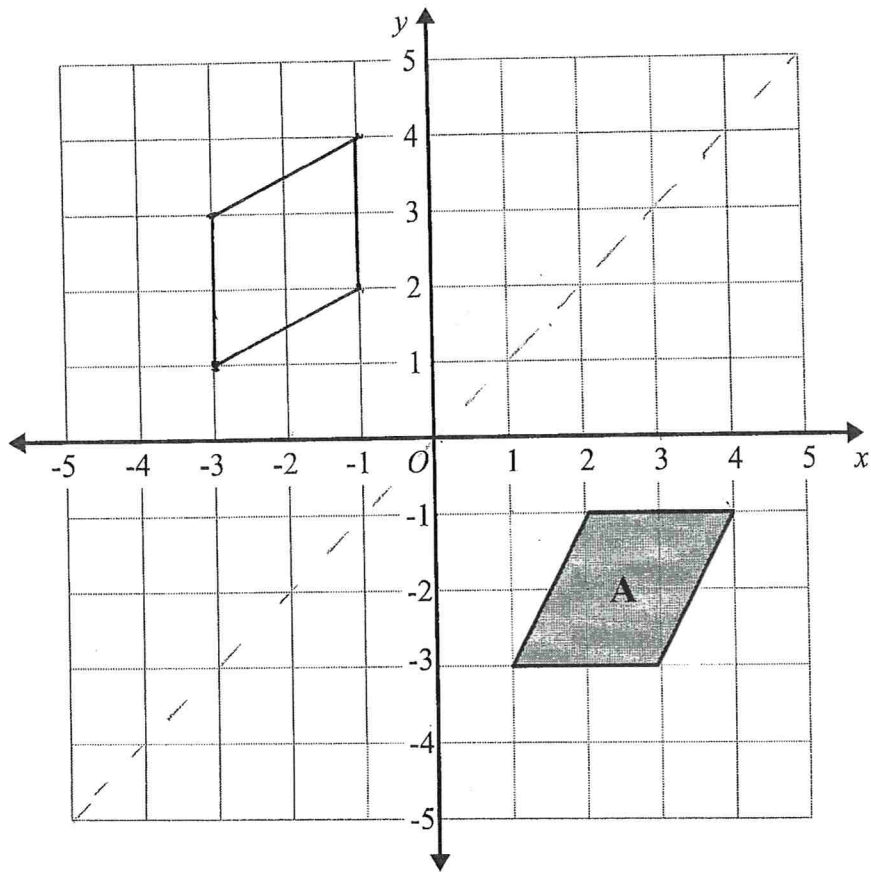

Reflect shape A in the line with equation $y = x$

(Total for question 4 is 2 marks)

5

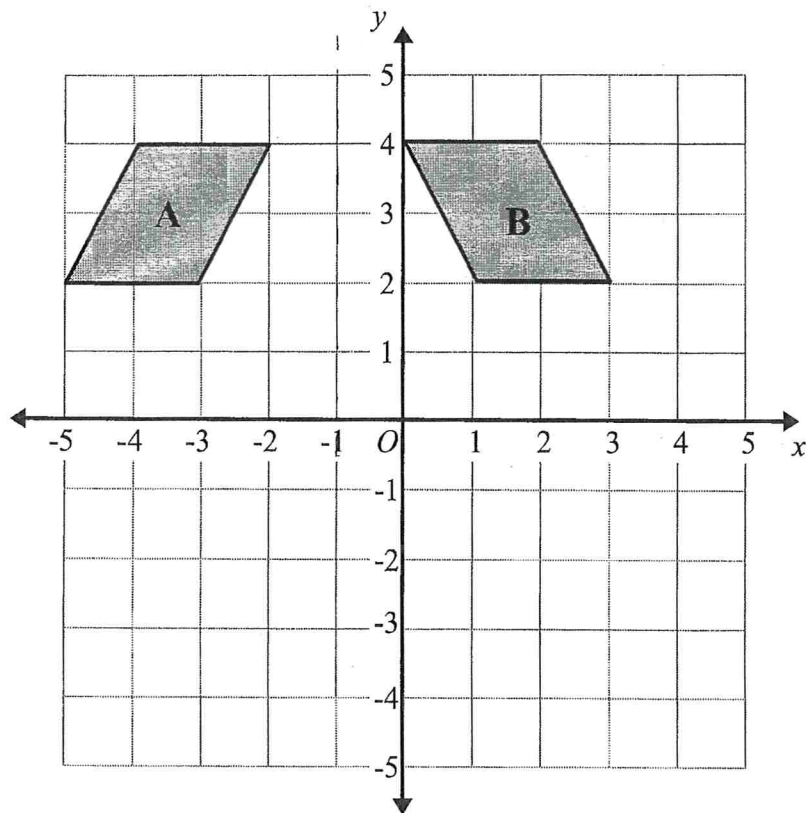

Describe fully the single transformation that maps shape A onto shape B.

Reflection in line $x = -1$

(Total for question 5 is 2 marks)

6

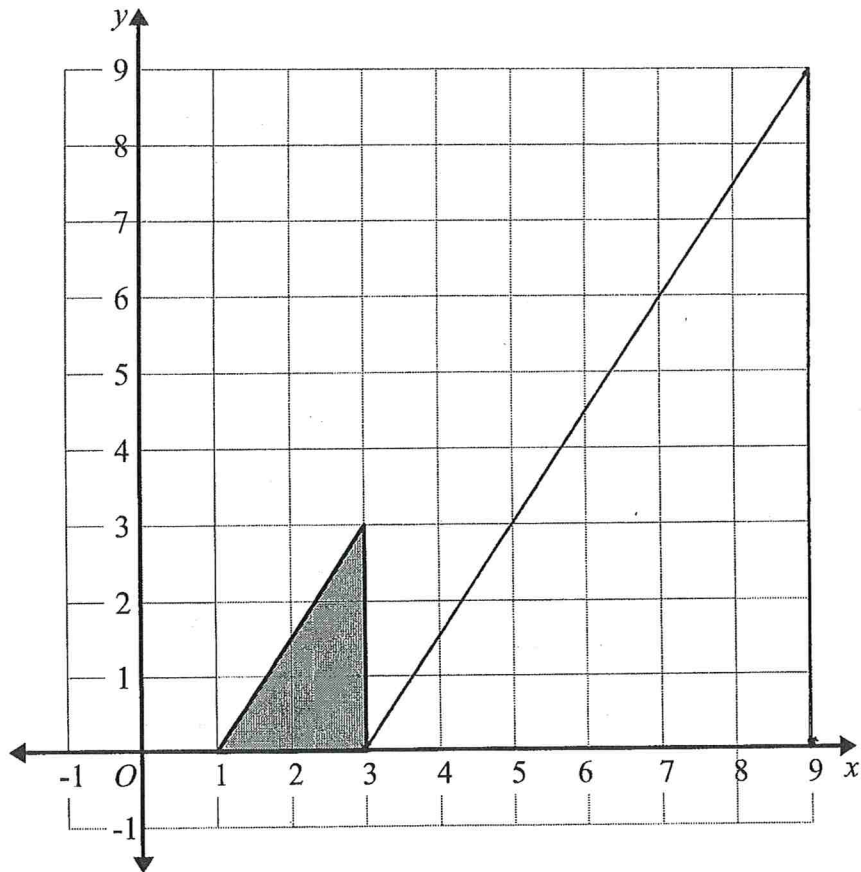

Enlarge the shaded triangle by scale factor 3, centre O

(Total for question 6 is 2 marks)

7

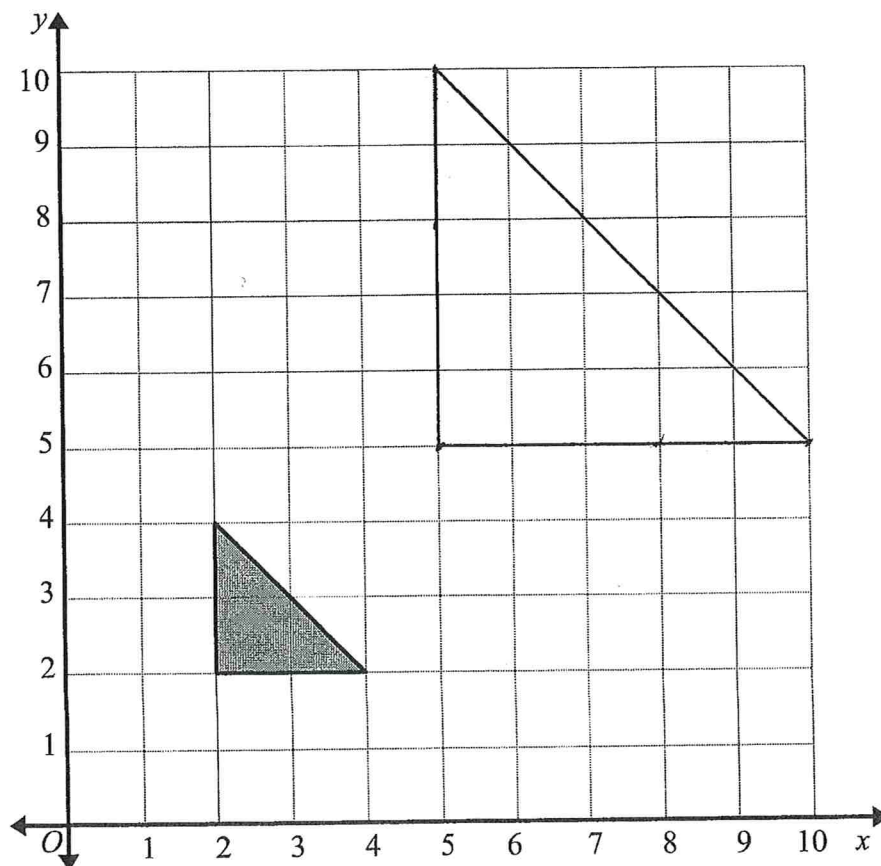

Enlarge the shaded triangle by scale factor 2.5, centre O .

(Total for question 7 is 2 marks)

8

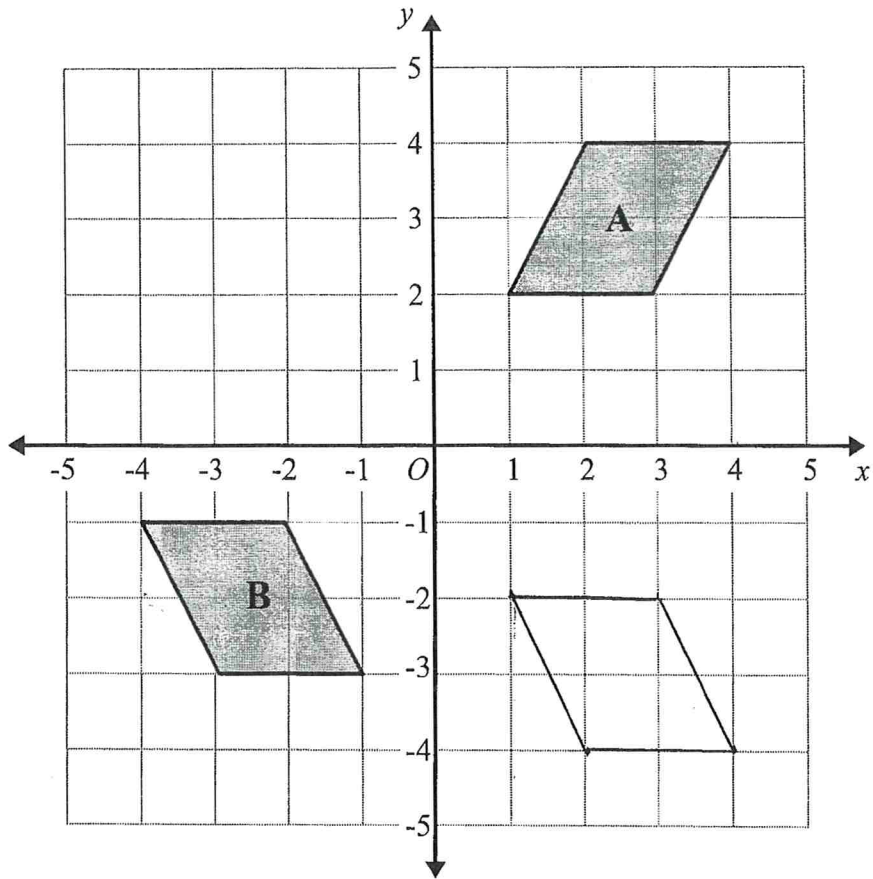

Shape **A** is transformed to shape **B** by a reflection in the x axis followed by a translation $\begin{pmatrix} p \\ q \end{pmatrix}$

Find the value of p and the value of q .

$$p = \dots -5 \dots$$

$$q = \dots 1 \dots$$

(Total for question 8 is 3 marks)

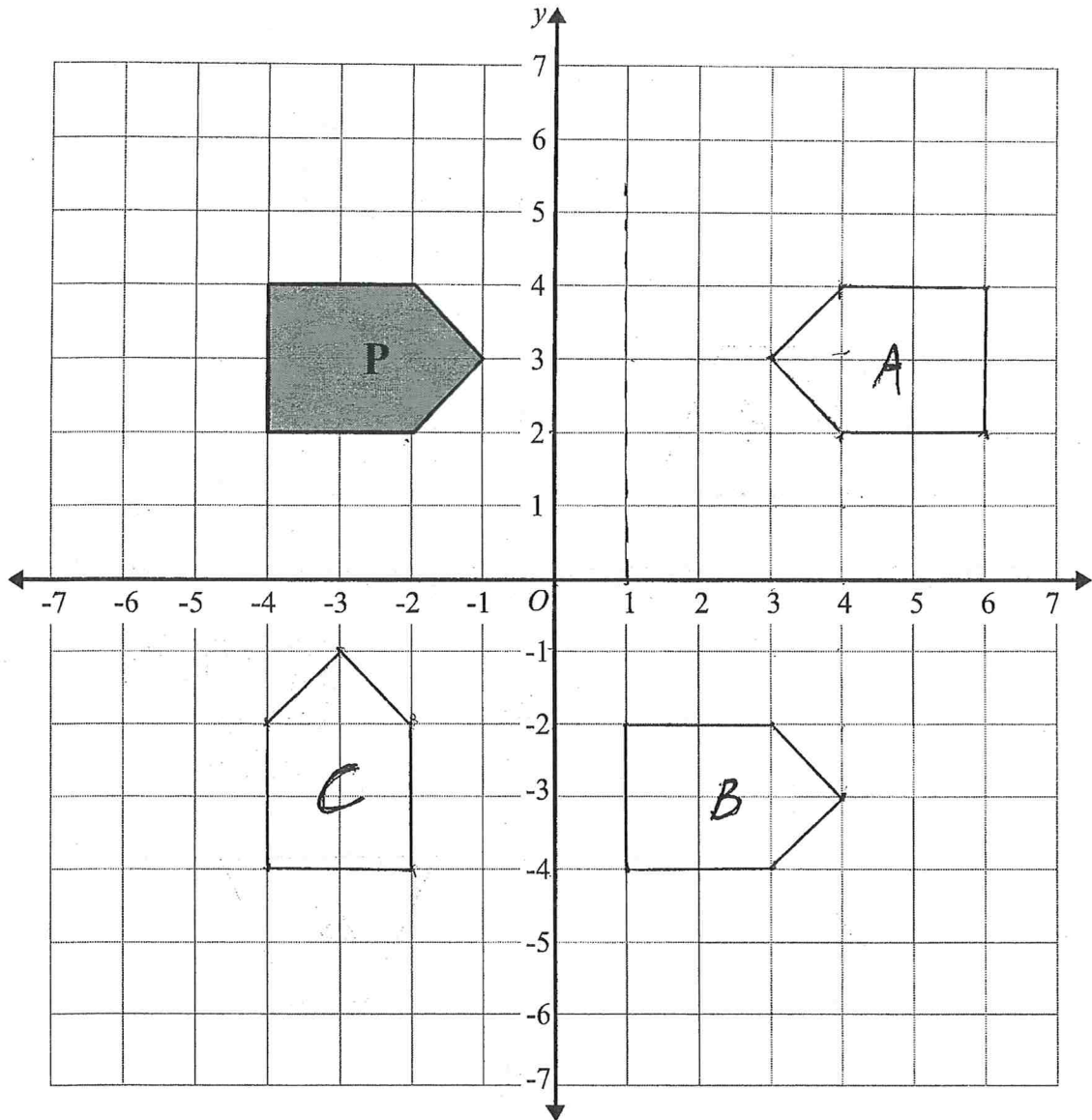

(a) Reflect shape **P** in the line $x = 1$.
Label the new shape **A**.

(b) Translate shape **P** by the vector $\begin{pmatrix} 5 \\ -6 \end{pmatrix}$
Label the new shape **B**.

(c) Rotate shape **P** by 90° anticlockwise, centre O
Label the new shape **C**

(Total for question 9 is 3 marks)

10

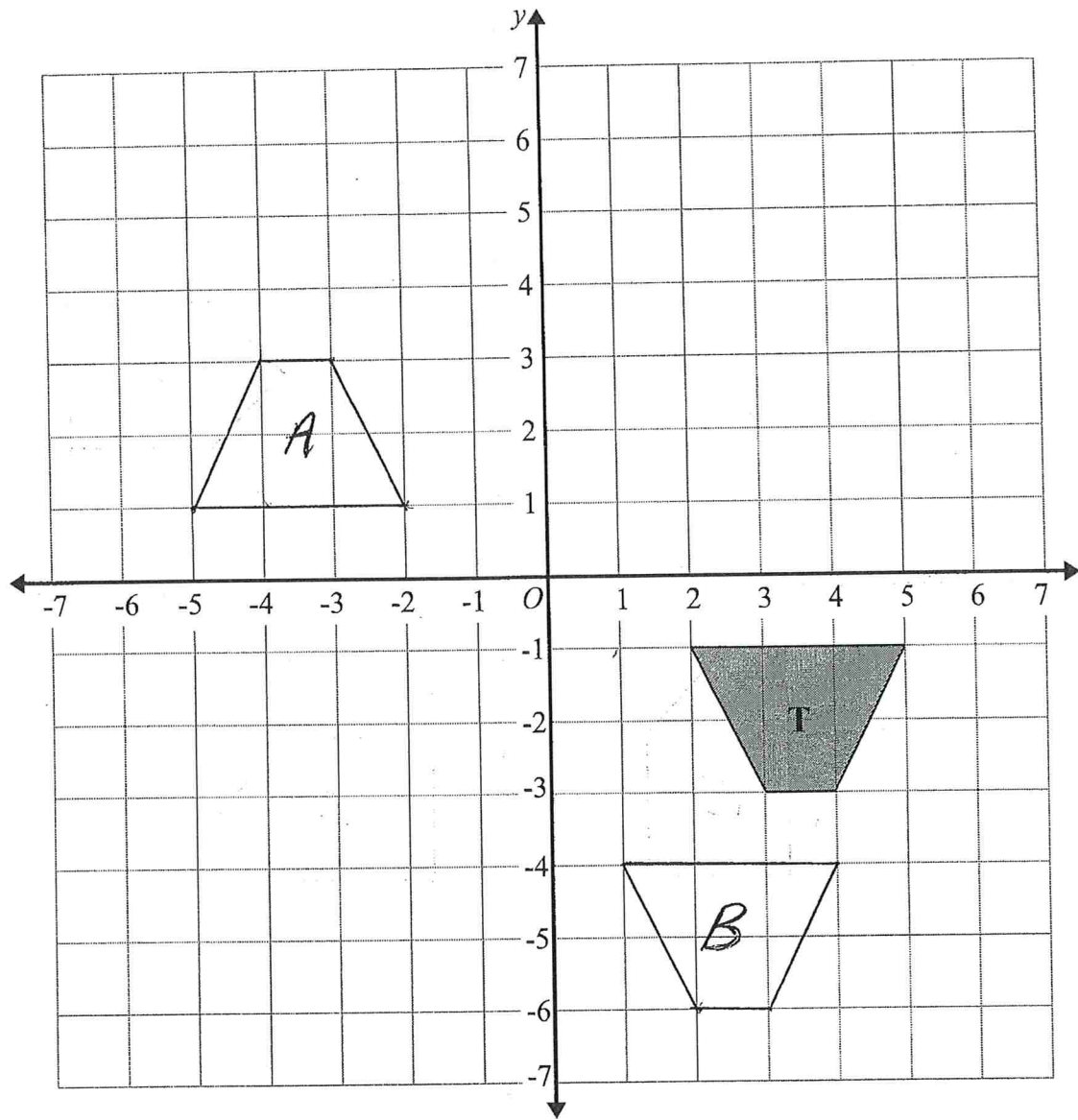

(a) Rotate trapezium **T** 180° about the origin.
Label the new trapezium **A**.

(b) Translate trapezium **T** by the vector $\begin{pmatrix} -1 \\ -3 \end{pmatrix}$
Label the new trapezium **B**.

(Total for question 10 is 2 marks)

1 Here are four angles A, B, C and D.

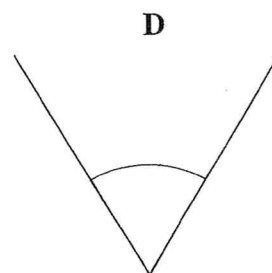
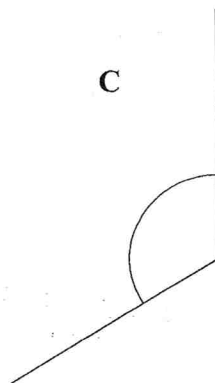
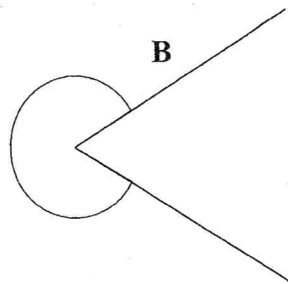
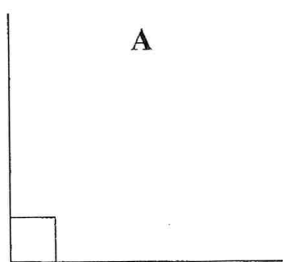

(a) Measure the size of angle C.

(b) Match the angle mathematical name to the angle.

120 °

Mathematical Name	Angle
Acute Angle	D
Obtuse Angle	C
Right Angle	A
Reflex Angle	B

(Total for question 7 is 3 marks)

2 In the space below draw an angle of 60°
Label the angle A.

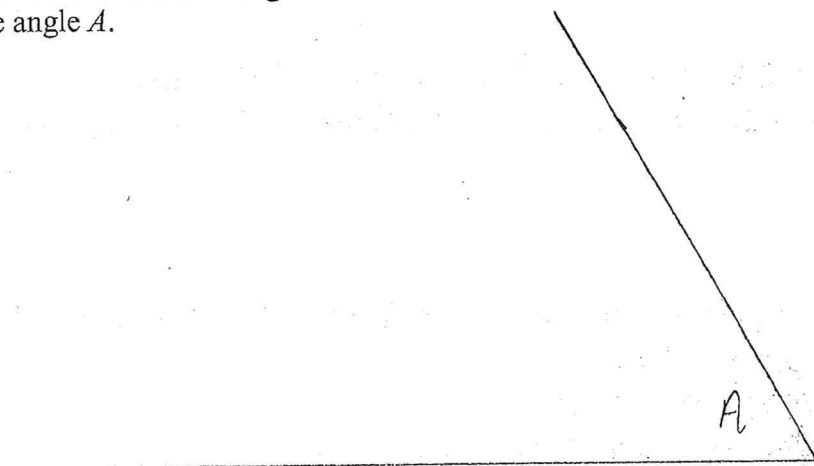

(Total for question 2 is 1 mark)

- 3 In the space below draw an angle of 110°
Label the angle B .

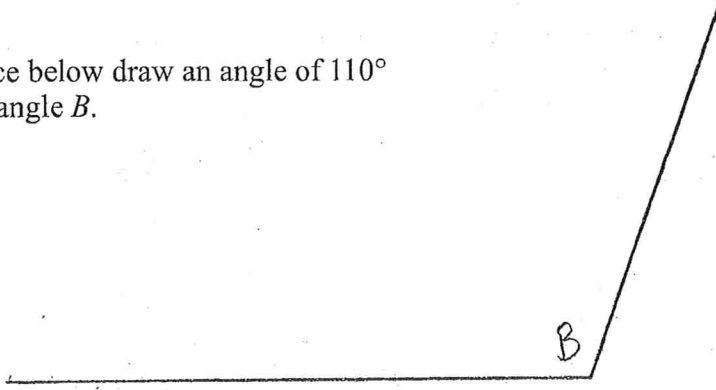

(Total for question 3 is 1 mark)

Diagrams are NOT accurately drawn, unless otherwise indicated.

- 4 ABC is a straight line. Work out the size of the angle marked x .

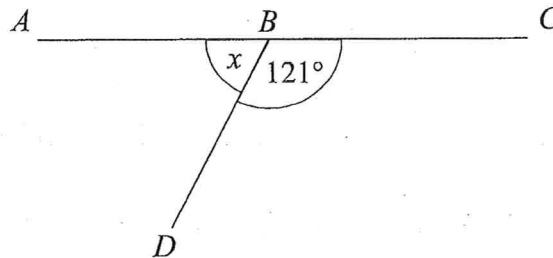

$$180 - 121$$

..... 59 °

(Total for question 4 is 2 marks)

- 5 Work out the size of the angle marked x .

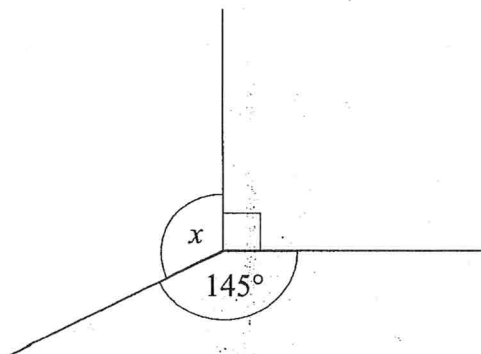

$$90 + 145 = 235$$

$$360 - 235 = 125$$

..... 125 °

(Total for question 5 is 2 marks)

- 6 AB and BC are perpendicular lines. Work out the size of the angle marked x .

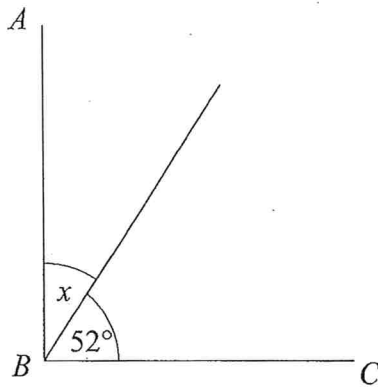

$$90 - 52$$

..... 38 °

(Total for question 6 is 2 marks)

- 7 ABC is an isosceles triangle. Work out the size of the angle marked x .

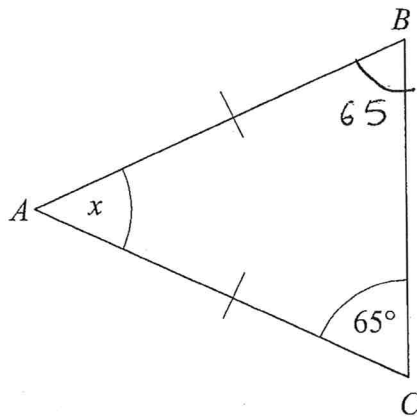

$$65 + 65 = 130$$

$$180 - 130 = 50$$

..... 50 °

(Total for question 7 is 2 marks)

8

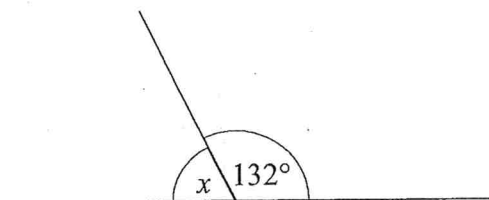

(a) Work out the size of the angle marked x .

$$180 - 132$$

48 °

(b) Give a reason for your answer.

Angles on a straight line add to 180 °

(Total for question 8 is 2 marks)

9 The diagram shows a square $ABDE$ and an equilateral triangle BCD .

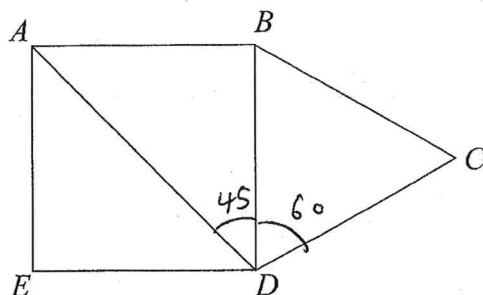

(a) Write down the size of angle ABD

90 °

(b) Write down the size of angle BCD

60 °

(c) Find the size of angle ADC

$$45 + 60$$

105 °

(Total for question 9 is 4 marks)

10

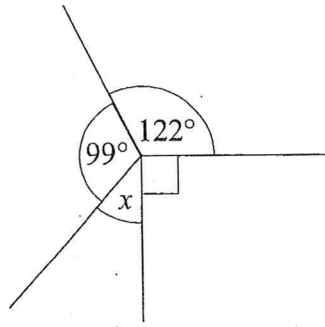

$$99 + 122 = 221$$

$$221 + 90 = 311$$

$$360 - 311 = 49$$

(a) Work out the size of the angle marked x .

_____ 49 _____ °

(b) Give a reason for your answer.

_____ Angles around a point add to 360° _____

(Total for question 10 is 2 marks)

11

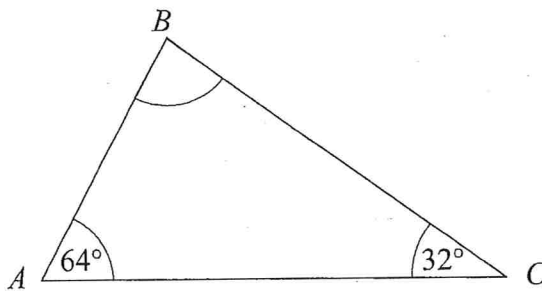

$$64 + 32 = 96$$

$$180 - 96 = 84$$

(a) Work out the size of the angle ABC .

_____ 84 _____ °

(b) Give a reason for your answer.

_____ Angles in a triangle add to 180° _____

(Total for question 11 is 2 marks)

12 ABC is a straight line. Work out the size of the angle BDC .

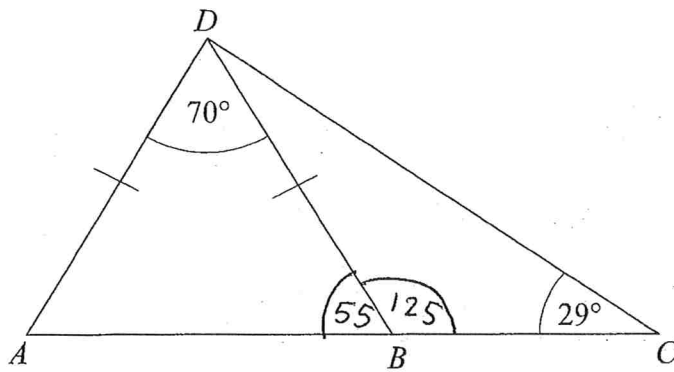

$$180 - 70 = 110$$

$$\frac{110}{2} = 55$$

$$180 - 55 = 125$$

$$125 + 29 = 154$$

$$180 - 154 = 26$$

26 °

(Total for question 12 is 4 marks)

13

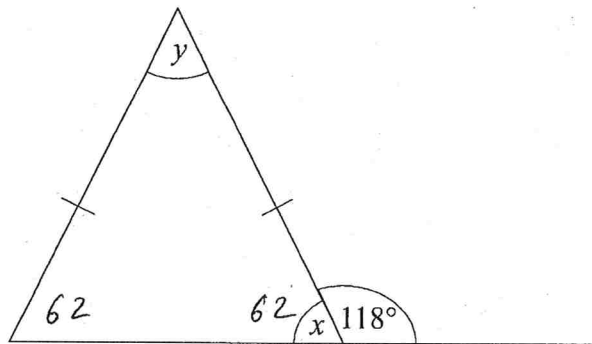

(a) Work out the size of the angle marked x .

$$180 - 118$$

62 °

(b) Work out the size of the angle marked y .

$$62 + 62 = 124$$

$$180 - 124$$

56 °

(c) Give a reason for your answer.

Angles at the base of an isosceles triangle are equal AND angles in a triangle add to 180°

(Total for question 13 is 3 marks)

14 ABC is a straight line.

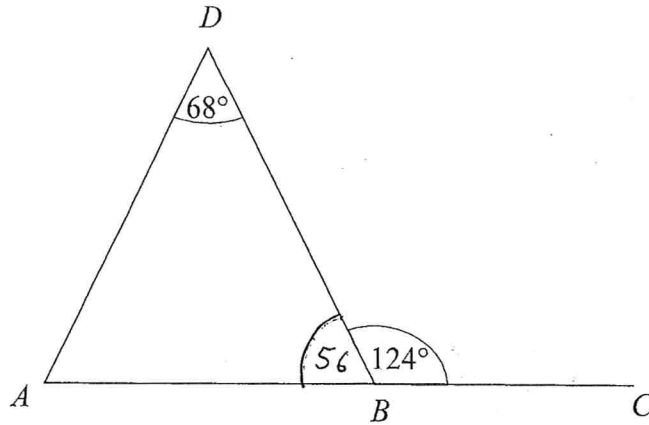

$$180 - 124 = 56$$

Show that ABD is an isosceles triangle

$ABD = 56^\circ$ Angles on a straight line
add to 180°

$$56 + 68 = 124$$

$$180 - 124 = 56$$

$\angle DAB = 56^\circ$ Angles in a triangle add
to 180°

Two angles equal \therefore isosceles triangle

(Total for question 14 is 4 marks)

1 The diagram shows two shapes on a centimetre grid.

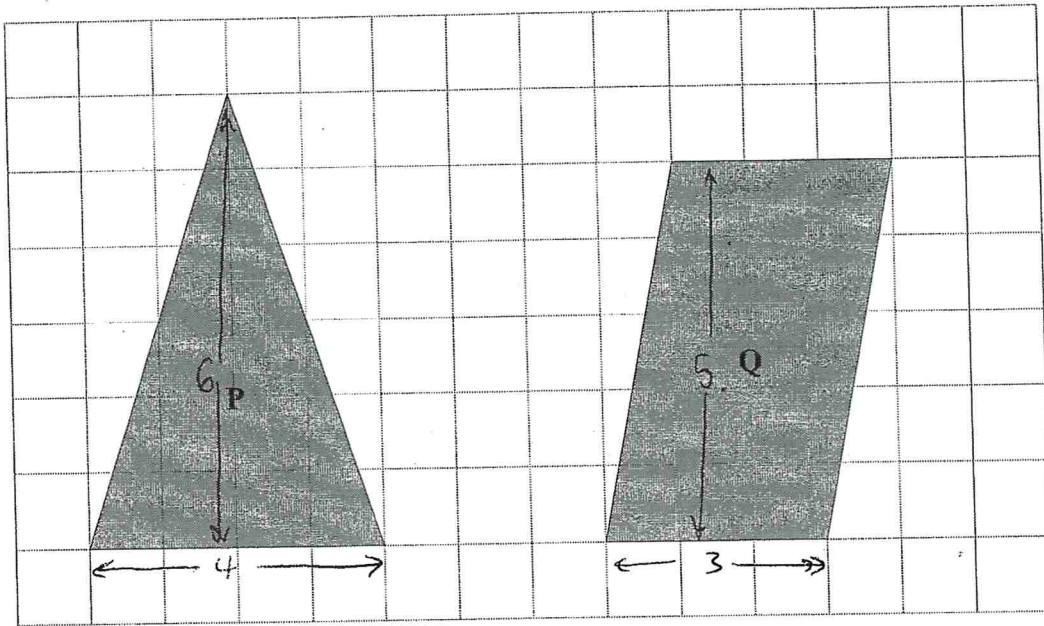

(a) Find the area of shape P

$$\frac{\text{base} \times \text{height}}{2}$$

$$\frac{4 \times 6}{2} = 12 \text{ cm}^2$$

..... 12 cm²

(b) Write down the mathematical name for shape Q.

..... parallelogram

(c) Find the area of shape Q.

base \times height

$$3 \times 5 = 15 \text{ cm}^2$$

..... 15 cm²

(Total for question 1 is 3 marks)

- 2 The length of a rectangle is two times the width of the rectangle.
The perimeter of the rectangle is 24 cm.

Draw the rectangle on the centimetre grid.

$$4 \times 8$$

width	length	perimeter
2	4	12
3	6	18
4	8	24 ✓

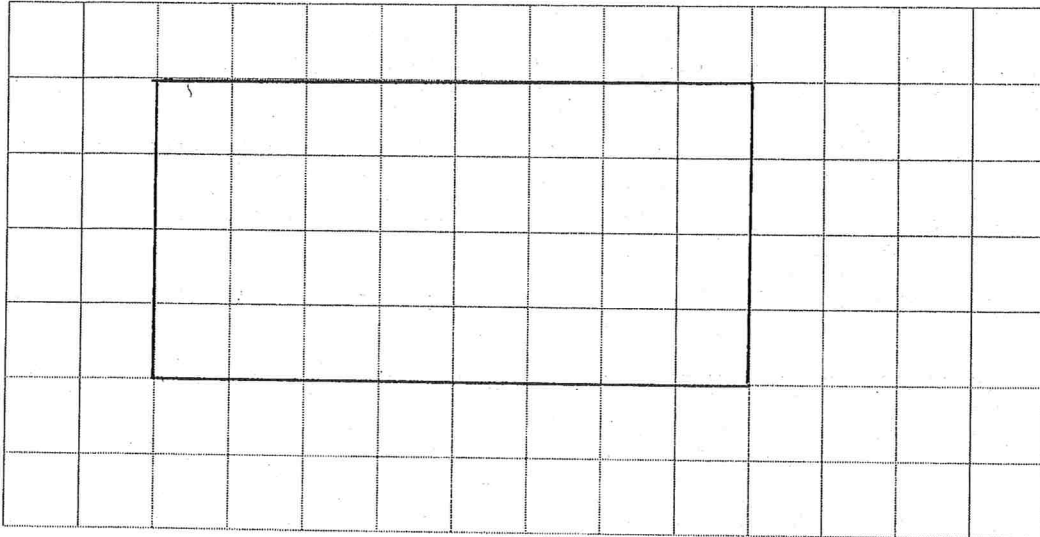

(Total for question 2 is 2 marks)

- 3 The length of a rectangle is three times the width of the rectangle.
The area of the rectangle is 48 cm².

Draw the rectangle on the centimetre grid.

$$4 \times 12$$

width	length	area
2	6	12
3	9	27
4	12	48 ✓

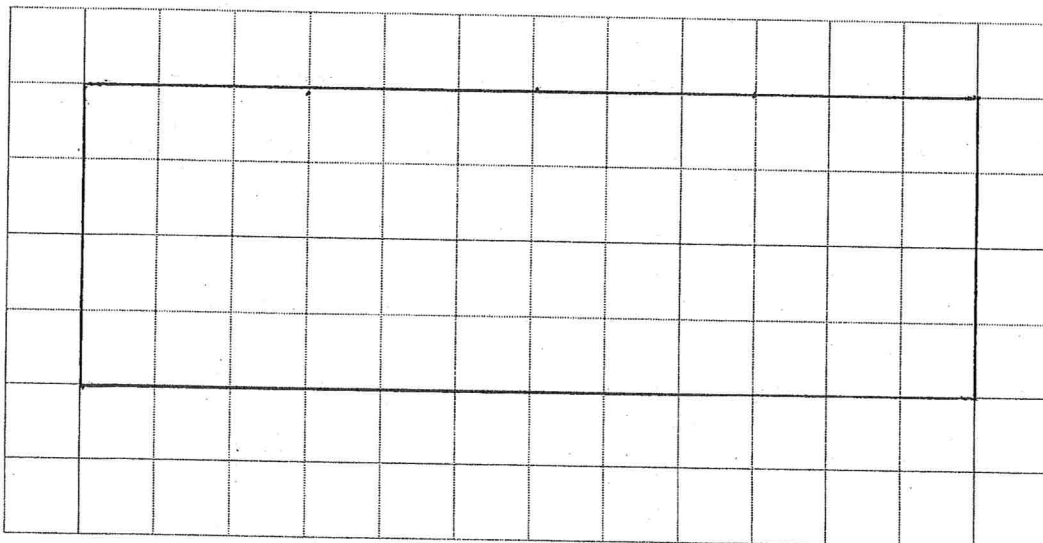

(Total for question 3 is 2 marks)

- 4 The base of a triangle twice the height of the triangle.
The area of a triangle is 16 cm^2 .

Draw the triangle on the centimetre grid.

$$\frac{\text{base} \times \text{height}}{2} = 16$$

$$\text{base} \times \text{height} = 32$$

height	base	$\frac{\text{base} \times \text{height}}{\text{area}}$
2	4	8
3	6	18
4	8	32 ✓

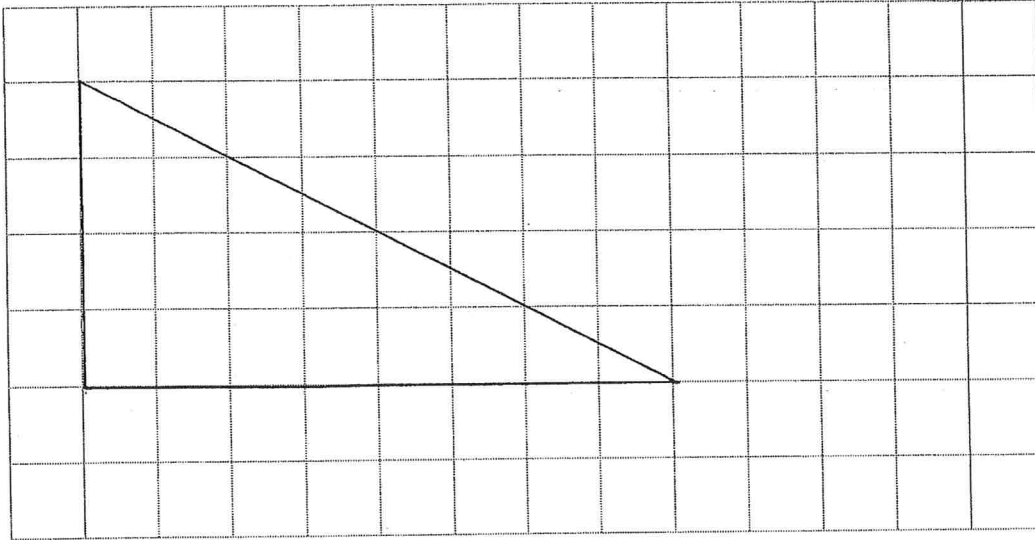

(Total for question 4 is 2 marks)

- 5 The base of a parallelogram twice the perpendicular height of the parallelogram.
The area of the parallelogram is 50 cm^2 .

Draw the parallelogram on the centimetre grid.

base	height	area
6	3	18
8	4	32
10	5	50 ✓

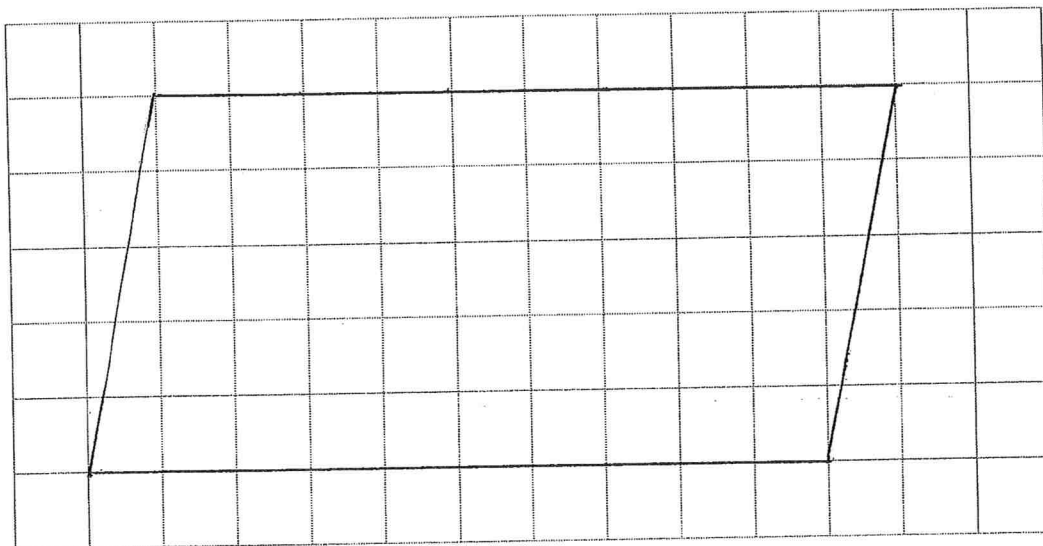

(Total for question 5 is 2 marks)

6 Here is a rectangle.

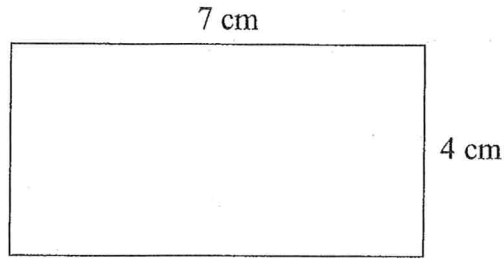

The six-sided shape below is made from two of these rectangles.

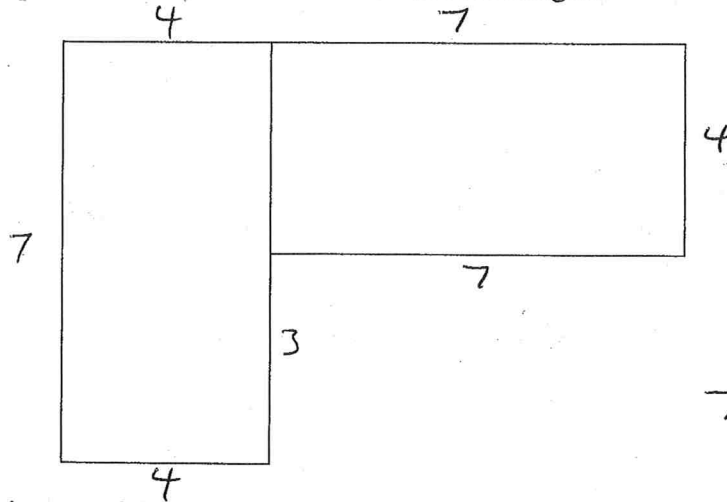

$$7 - 4 = 3$$

Work out the perimeter of this six-sided shape.

$$7 + 4 + 7 + 4 + 7 + 3 + 4$$

$$\underline{\quad 36 \quad} \text{ cm}$$

(Total for question 6 is 3 marks)

7 A square has an area of 64 cm^2 .

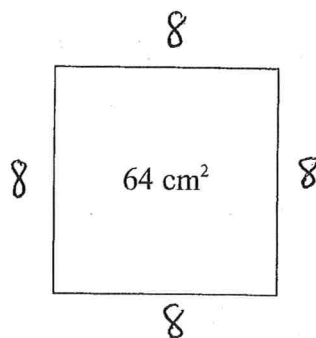

$$8 \times 8 = 64$$

Find the perimeter of the square.

$$4 \times 8 = 32$$

$$\underline{\quad 32 \quad} \text{ cm}$$

(Total for question 7 is 2 marks)

8 A square has a perimeter of 36 cm.

Find the area of the square.

$$\frac{36}{4} = 9$$

$$9 \times 9 = 81$$

..... 81 cm²

(Total for question 8 is 2 marks)

9 The diagram shows a right angled triangle and a parallelogram.

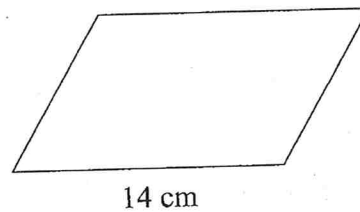
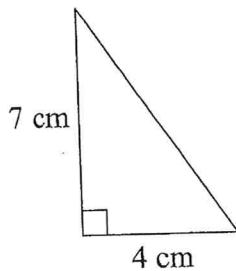

The area of the parallelogram is four times the area of the triangle.

The perpendicular height of the parallelogram is h .

Find the value of h .

$$\text{Area of triangle} = \frac{4 \times 7}{2} = 14 \text{ cm}^2$$

$$4 \times 14 = 56 \text{ cm}^2$$

$$14 \times h = 56$$

$$h = \frac{56}{14} = \frac{28}{7} = 4$$

$h =$ 4

(Total for question 9 is 3 marks)

- 10 The diagram shows a garden in the shape of a trapezium.

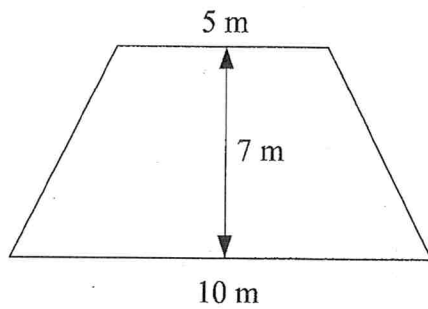

Find the area of the garden.

$$\begin{aligned} & \frac{1}{2}(a+b) \times h \\ & \frac{1}{2}(5+10) \times 7 \\ & \frac{1}{2}(15) \times 7 \\ & 7.5 \times 7 \end{aligned}$$

$$52.5 \text{ m}^2$$

(Total for question 10 is 3 marks)

- 11 Here is a trapezium drawn on a centimetre grid.

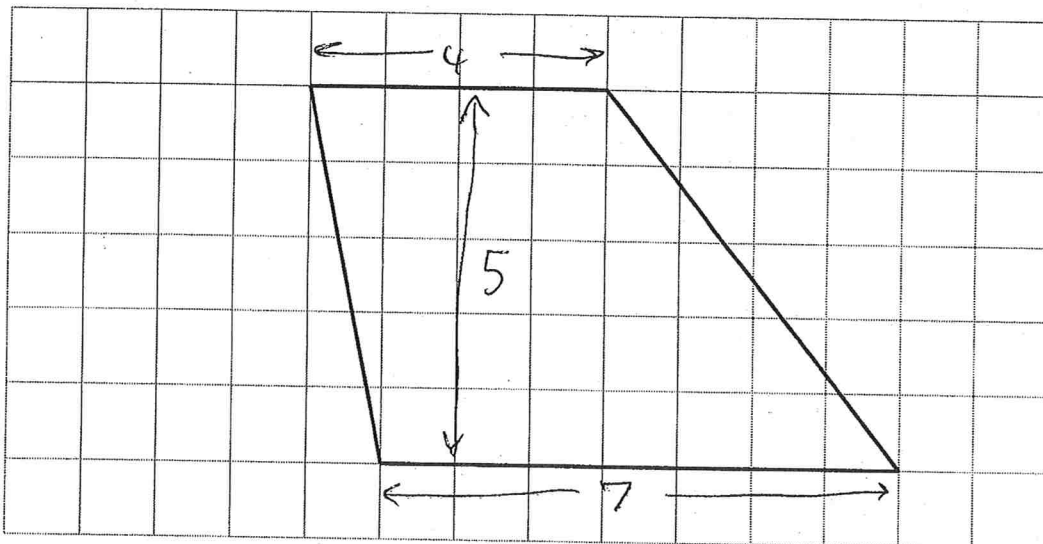

Find the area of the trapezium.

$$\begin{aligned} & \frac{1}{2}(4+7) \times 5 \\ & \frac{1}{2}(11) \times 5 \\ & 5.5 \times 5 \end{aligned}$$

$$27.5 \text{ cm}^2$$

(Total for question 11 is 2 marks)

- 12 The diagram shows a trapezium with an area of 30 cm^2 and a perpendicular height $h \text{ cm}^2$.

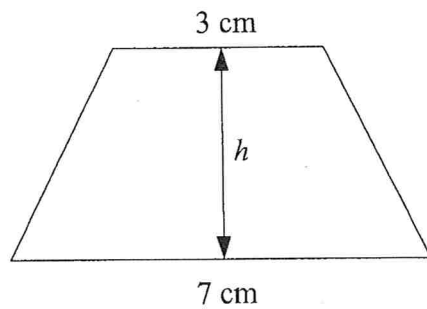

Find the value of h .

$$\frac{1}{2} (3 + 7) \times h = 30$$

$$\frac{1}{2} (10) \times h = 30$$

$$5 \times h = 30$$

$$h = 6$$

$$h = \underline{\quad 6 \quad} [\text{cm}]$$

(Total for question 12 is 2 marks)

- 13 The diagram shows a trapezium with an area of 45 cm^2 and a perpendicular height $h \text{ cm}^2$.

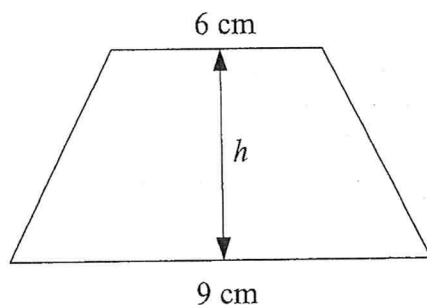

Find the value of h .

$$\frac{1}{2} (6 + 9) \times h = 45$$

$$\frac{1}{2} (15) \times h = 45$$

$$7.5 h = 45$$

$$h = \frac{45}{7.5} = 6$$

$$h = \underline{\quad 6 \quad} [\text{cm}]$$

(Total for question 13 is 2 marks)

4 Jo is going to play one tennis match and match of squash.

The probability she will win the tennis match is $\frac{4}{5}$

The probability she will win the squash match is $\frac{7}{10}$

(a) Complete the probability tree diagram.

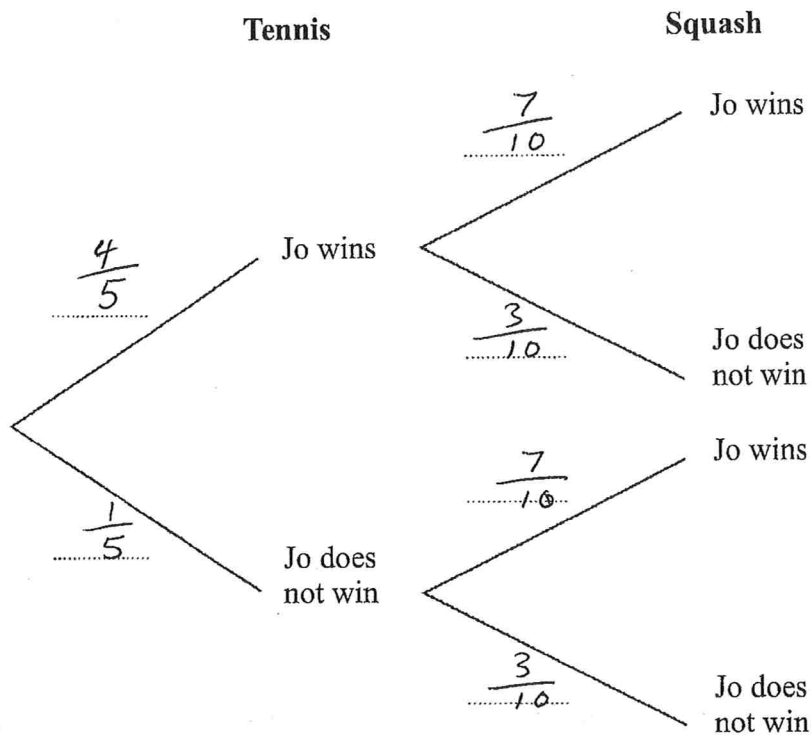

(2)

(b) Work out the probability that Jo will win both matches.

$$\frac{4}{5} \times \frac{7}{10} = \frac{28}{50}$$

$$\frac{28}{50}$$

(2)

(Total for question 4 is 4 marks)

$$\left[\frac{14}{25} \right]$$

6 Jon plays a game where he can win, draw or lose.

The probability Jon wins any game 0.5.
The probability Jon draws any game is 0.3

Jon plays two games.

(a) Complete the probability tree diagram

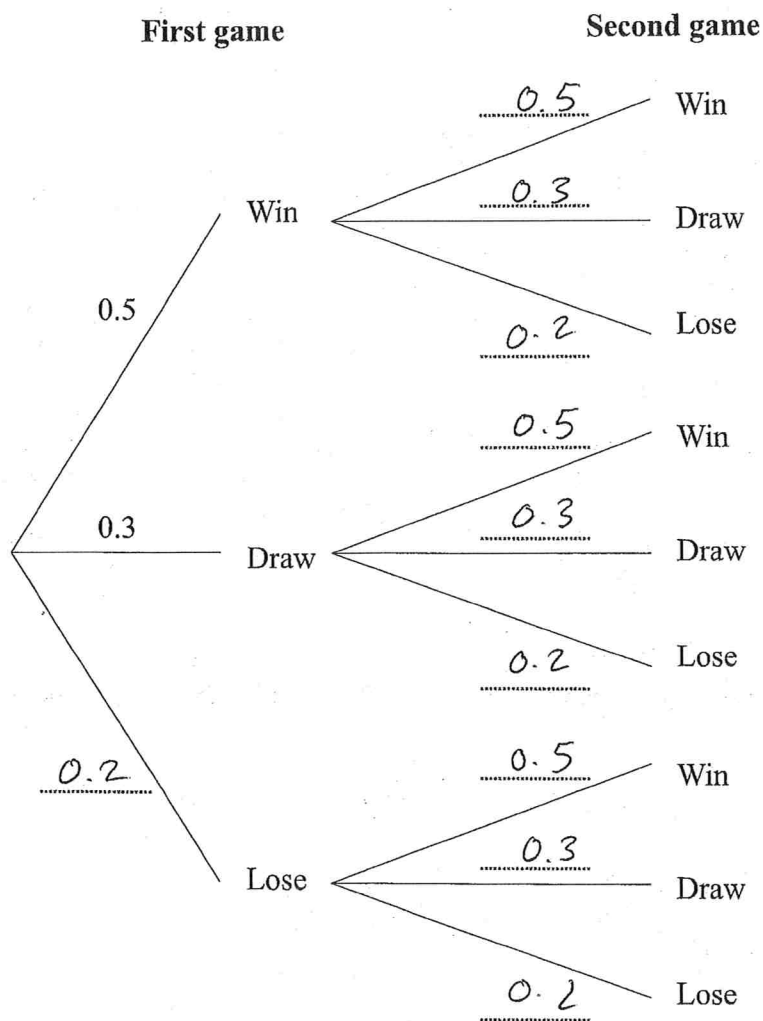

(b) Work out the probability Jon wins both games.

(2)

$$0.5 \times 0.5 = 0.25$$

0.25

(2)

(Total for question 6 is 4 marks)

7

Bradley gets the bus on Saturday and Sunday.
The probability that Bradley's bus will be late on any day is 0.2

(a) Complete the probability tree diagram.

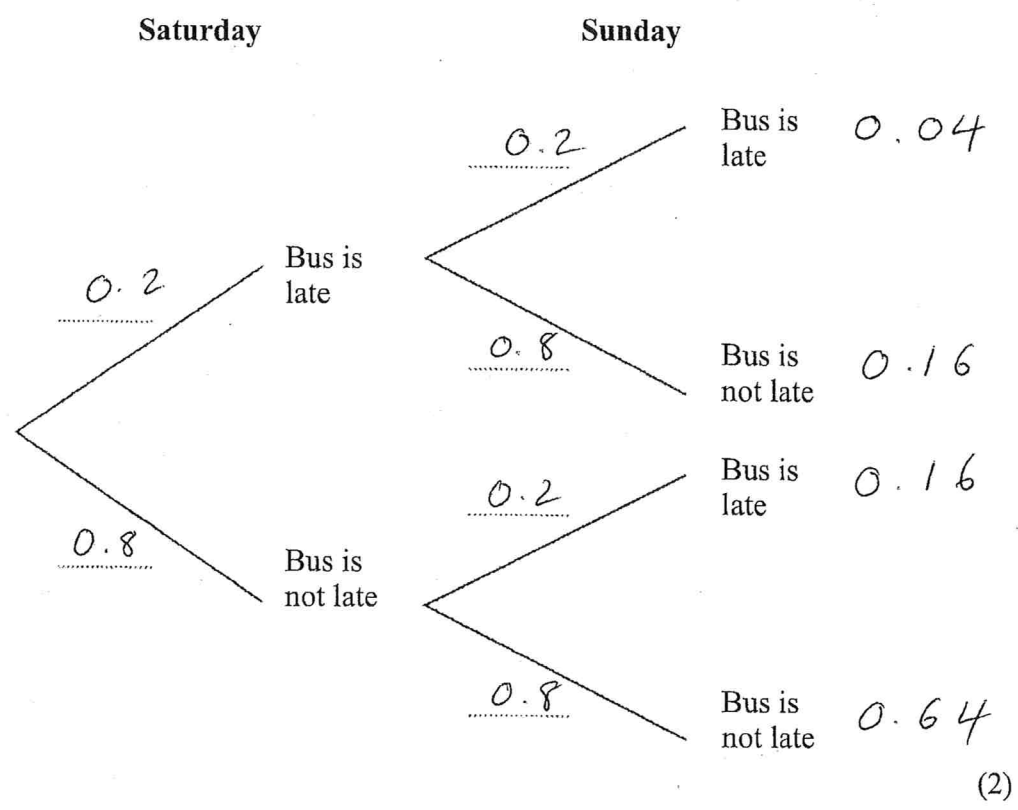

(b) Work out the probability that Bradley's bus is late on at least one of these days.

$$0.2 \times 0.2 = 0.04$$

$$0.2 \times 0.8 = 0.16$$

$$0.8 \times 0.2 = 0.16$$

$$0.04 + 0.16 + 0.16 = \underline{\underline{0.36}}$$

(2)

(Total for question 7 is 4 marks)

1 The two way table gives information about how 100 students travelled to school.

	Walk	Car	Other	Total
Boys	15	26	11	52
Girls	18	22	8	48
Total	33	48	19	100

(a) Complete the two way table.

(3)

One of the students is picked at random.

(b) Write down the probability they walk to school.

$$\frac{33}{100}$$

(1)

(Total for question 1 is 4 marks)

2 The two way table gives information about the favourite sport of 150 students.

	Football	Rugby	Other	Total
Boys	35	17	21	73
Girls	42	4	31	77
Total	77	21	52	150

Complete the two way table.

(Total for question 2 is 3 marks)

3 The two way table gives information about the favourite subject of 200 students.

	Maths	English	Other	Total
Year 10	41	31	26	98
Year 11	47	10	45	102
Total	88	41	71	200

(a) Complete the two way table.

(3)

One of the students is picked at random.

(b) Write down the probability they are a year 10 student whose favourite subject is maths.

$$\frac{41}{200}$$

(1)

(Total for question 3 is 4 marks)

- 4 There are 170 students in year 7 at a school.
All of these students either walk to school, get the bus to school or cycle to school.

82 of the students are boys.
33 of the students get the bus to school.
19 of the 41 students that walk to school are boys.
56 girls cycle to school.

Complete the two way table.

	Walk	Bus	Cycle	Total
Boys	19	23	40	82
Girls	22	10	56	88
Total	41	33	96	170

(Total for question 4 is 3 marks)

- 5 A football team played 38 games.
19 games were played at home and the rest were played away.

The team won a total of 21 games.
They drew 4 games away.
2 of the 10 games they lost were at home.

Complete the two way table.

	Won	Drawn	Lost	Total
Home	14	3	2	19
Away	7	4	8	19
Total	21	7	10	38

(Total for question 5 is 3 marks)

6 100 students attended a revision lesson at the weekend.

Each student went to Maths or English or Science.

55 of these students attended on Saturday.

Over the weekend a total of 40 students went to Maths.

12 of the 27 students that went to Science went on Sunday.

10 students went to English on Saturday.

How many students went to the Maths revision lesson on Saturday?

	Maths	English	Science	Total
Saturday	30	10	15	55
Sunday	10	23	12	45
Total	40	33	27	100

.....30.....

(Total for question 6 is 4 marks)

7 120 students are asked whether they like biology or chemistry or physics best.

52 of the students are in year 11, the rest are in year 10.

45 students like physics best.

20 of the year 11 students like biology best

16 of the 30 students who like chemistry best are in year 10.

Work out how many year 10 students like physics best.

	Biology	Chemistry	Physics	Total
Year 10	25	16	27	68
Year 11	20	14	18	52
Total	45	30	45	120

27

(Total for question 7 is 4 marks)

8 100 students in year 7 either study French or German or Spanish.

45 of the students are boys and the rest are girls.

12 boys study German.

15 boys and 17 girls study French.

A total of 30 students study Spanish.

Work out how many girls study Spanish.

	French	German	Spanish	Total
Boys	15	12	18	45
Girls	17	26	12	55
Total	32	38	30	100

.....
12

(Total for question 8 is 4 marks)

9 Two different schools, school A and school B, attended a conference.

12% of the attendees were teachers, the rest were students.

47% of the attendees were from school A.

48% of the attendees were **students** from school B.

One of the attendees is selected at random.

Find the probability that they are a teacher from school A.

	Students	Teachers	Total
School A	40	7	47
School B	48	5	53
Total	88	12	100

..... 7%

(Total for question 9 is 4 marks)

OR $\frac{7}{100}$ OR 0.07

10 300 students are asked how they get to school.

All of the students either walk to school or get the bus to school.

58% of the students walk to school. 174 $[0.58 \times 300 = 174]$

45% of the students are boys. 135 $[0.45 \times 300 = 135]$

21% of the boys ^{wh} get the bus to school. 63 $[0.21 \times 300 = 63]$
students are

Work out how many girls walk to school.

	Walk	Bus	Total
Boys	72	63	135
Girls	102	63	165
Total	174	126	300

.....102

(Total for question 10 is 4 marks)

- 1 The table shows information about the number of points scored in a game.

Points		Frequency	
0	X	9	0
1	X	11	11
2	X	18	36
3	X	7	21
4	X	4	16
5	X	1	5

Work out the mean number of points per game.

50 89

$$\frac{89}{50} = \frac{178}{100} = 1.78$$

..... 1.78

(Total for question 1 is 3 marks)

- 2 The table shows information about the number of goals scored in a game by a football team.

Points	Frequency	
0	10	0
1	12	12
2	x	$2x$
3	7	21
4 or more	0	0

The team scored a total of 55 goals.
Find the value of x .

$$12 + 2x + 21 = 55$$

$$2x + 33 = 55$$

$$2x = 22$$

$$x = 11$$

..... 11

(Total for question 2 is 3 marks)

3 The table shows information about the number of goals a team scored in 38 games.

Points	Frequency
0	7
1	14
2	11
3	6
4 or more	0

(a) Find the median number of goals scored.

.....
|
.....
(1)

(b) Write down the mode

.....
|
.....
(1)

(c) Work out the total number of goals the team scored in all 38 games.

$$\begin{aligned}0 \times 7 &= 0 \\1 \times 14 &= 14 \\2 \times 11 &= 22 \\3 \times 6 &= 18\end{aligned}$$

$$14 + 22 + 18 = 54$$

.....
54
.....
(2)

(Total for question 3 is 4 marks)

4 Adam is measuring the heights in cm of his tomato plants.

Height (cm)	m.p	x	Frequency	m.p x f
140 < h ≤ 150	145	x	7	1015
150 < h ≤ 160	155	x	10	1550
160 < h ≤ 170	165	x	15	2475
170 < h ≤ 180	175	x	19	3325
180 < h ≤ 200	190	x	9	1710
			60	10075

(a) Estimate the mean height.
Give your answer correct to 1 decimal place.

$$\frac{10075}{60} = 167.9 \text{ (1dp)}$$

.....167.9.....cm
(3)

(b) Explain why your answer to part (a) is an estimate.

.....we do not know the exact height of each.....
.....plant as the data is grouped.....
(we use the midpoint to estimate the heights of plants (1)
(Total for question 4 is 4 marks)
in each group)

5 The table below gives information about the time taken for 20 people to run 5 km.

Time (minutes)	m.p	Frequency	$m.p \times f$
$15 < t \leq 20$	17.5	3	52.5
$20 < t \leq 25$	22.5	6	135
$25 < t \leq 30$	27.5	7	192.5
$30 < t \leq 40$	35	4	140
			520

(a) Find the class interval that contains the median.

25 < t ≤ 30.....minutes
(1)

(b) Work out an estimate for the mean time.

$$\frac{520}{20} = 26$$

.....26.....minutes
(3)

(Total for question 5 is 4 marks)

6 Michael recorded the maximum temperature every day in September.

The table shows information about his results.

Temperature ($^{\circ}\text{C}$)	mp		Frequency	$mp \times f$
$14 < t \leq 18$	16	\times	4	64
$18 < t \leq 20$	19	\times	10	190
$20 < t \leq 22$	21	\times	8	168
$22 < t \leq 24$	23	\times	5	115
$24 < t \leq 28$	26	\times	3	78

Calculate an estimate for the mean maximum temperature.

615

$$\frac{615}{30} = 20.5$$

.....20.5..... $^{\circ}\text{C}$

(Total for question 6 is 3 marks)

7 The frequency table shows the time taken for 100 people to travel to an event.

Time (minutes)	mp		Frequency	$mp \times f$
$0 < t \leq 10$	5	\times	14	70
$10 < t \leq 20$	15	\times	16	240
$20 < t \leq 30$	25	\times	23	575
$30 < t \leq 40$	35	\times	29	1015
$40 < t \leq 50$	45	\times	12	540
$50 < t \leq 60$	55	\times	6	330
				2770

(a) Find the percentage of people that travelled for more than 30 minutes to the event

$$29 + 12 + 6 = 47$$

$$\frac{47}{100} = 47\%$$

..... 47 %
(1)

(b) Find the class interval that contains the median.

..... $20 < t \leq 30$ minutes
(1)

(c) Find an estimate for the mean time taken for people to travel to the event.

$$\frac{2770}{100} = 27.7$$

..... 27.7 minutes
(3)

(Total for question 7 is 5 marks)

8 The bar chart shows how many hours of homework 30 students did last week.

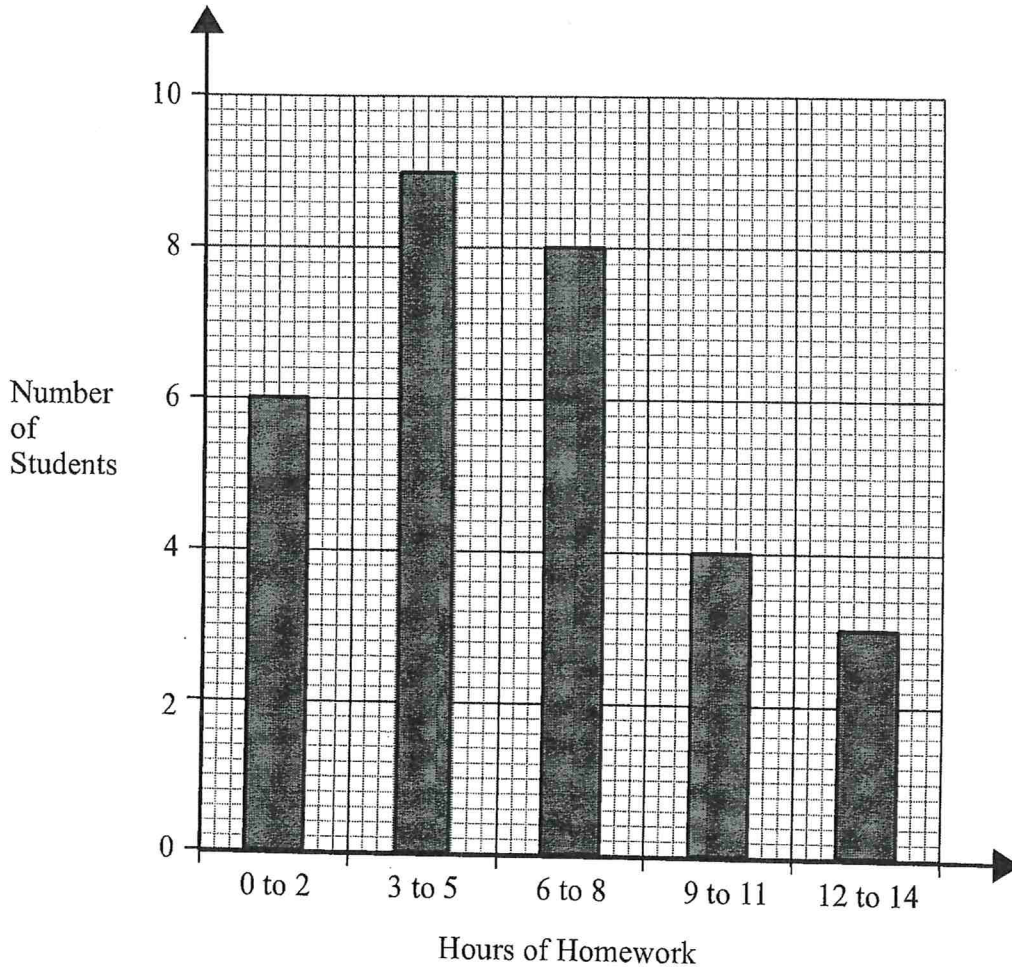

Calculate an estimate for the mean number of hours of homework.
~~Give your answer to 2 decimal places.~~

$$\begin{aligned}
 1 \times 6 &= 6 \\
 4 \times 9 &= 36 \\
 7 \times 8 &= 56 \\
 10 \times 4 &= 40 \\
 13 \times 3 &= 39
 \end{aligned}$$

$$177$$

$$\frac{177}{30} = 5.9$$

..... 5.9 hours

(Total for question 8 is 3 marks)

1 Here is a list of 10 numbers.

2 3 4 4 4 5 6 6 7 7

(a) Work out the range.

$$7 - 2 = 5$$

5

(1)

(b) Find the mode.

4

(1)

(c) Calculate the mean.

$$2 + 3 + 4 + 4 + 4 + 5 + 6 + 6 + 7 + 7 = 48$$

$$\frac{48}{10} = 4.8$$

4.8

(2)

(Total for question 14 is 4 marks)

2 Here is a list of 5 numbers.

4 6 9 10 11

(a) Work out the range.

$$11 - 4 = 7$$

7

(1)

(b) Write down the median.

9

(1)

(c) Calculate the mean.

$$4 + 6 + 9 + 10 + 11 = 40$$

$$\frac{40}{5} = 8$$

8

(2)

(Total for question 2 is 4 marks)

3 Here are the heights, in cm, of 8 people.

155 171 164 171 167 188 190 151

(a) Work out the range.

$$190 - 151$$

$$\dots\dots\dots 39 \dots\dots \text{cm}$$

(1)

(b) Find the mode.

(c) Calculate the mean.

$$\dots\dots\dots 171 \dots\dots \text{cm}$$

(1)

$$155 + 171 + 164 + 171 + 167 + 188 + 190 + 151$$
$$= 1357$$

$$\frac{1357}{8} = 169.625 \quad \dots\dots\dots 169.625 \text{ cm}$$

(2)

(Total for question 3 is 4 marks)

4 Here are the weights, in grams, of 6 potatoes

150 129 125 133 144 105

(a) Work out the range.

$$150 - 105 = 45$$

$$\dots\dots\dots 45 \dots\dots$$

(1)

(b) Work out the median weight.

105 125 129 133 144 150

↑

$$\frac{129 + 133}{2} = 131$$

$$\dots\dots\dots 131 \dots\dots \text{g}$$

(2)

(Total for question 4 is 3 marks)

5 Here are six cards. Each card has a number on it.

19	7	11	8	15	15
----	---	----	---	----	----

(a) Work out the range of the numbers on the cards.

$$19 - 7 = 12$$

$$\begin{array}{r} 12 \\ \hline \end{array} \quad (1)$$

(b) Work out the mean of the numbers on the cards.

$$\cancel{19 + 7}$$

$$19 + 11 + 15 + 15 + 8 + 7 = 75$$

$$\frac{75}{6} = 12.5$$

$$\begin{array}{r} 12.5 \\ \hline \end{array} \quad (2)$$

(Total for question 5 is 3 marks)

6 Here is a list of 10 numbers.

1 4 4 5 6 8 11 11 11 14

(a) Work out the range.

$$14 - 1 = 13$$

$$\begin{array}{r} 13 \\ \hline \end{array} \quad (1)$$

(b) Find the mode.

$$\begin{array}{r} 11 \\ \hline \end{array} \quad (1)$$

(Total for question 6 is 2 marks)

7

Here are seven cards. Each card has a number on it.

12	5	10	18	12	11	9
----	---	----	----	----	----	---

(a) Work out the range of the numbers on the cards.

$$18 - 5 = 13$$

$$\begin{array}{r} 13 \\ \hline \end{array}$$

(1)

(b) Work out the median of the numbers on the cards.

$$5 \quad 9 \quad 10 \quad 11 \quad 12 \quad 12 \quad 18$$

↑

$$\begin{array}{r} 11 \\ \hline \end{array}$$

(2)

(c) Work out the mean of the numbers on the cards.

$$5 + 9 + 10 + 11 + 12 + 12 + 18 = 77$$

$$\frac{77}{7} = 11$$

$$\begin{array}{r} 11 \\ \hline \end{array}$$

(2)

(Total for question 18 is 5 marks)

8

Here is a list of numbers.

8 6 4 5 9 8

(a) Work out the median

4 5 6 8 8 9
↑

$$\frac{6 + 8}{2} = 7$$

.....
7
.....
(2)

Here are six cards.

There is a number on each card.

Two of the numbers are hidden.

4 5 ? 6 3 ?

The mode of the six numbers is 4

The mean of the six numbers is 5

Work out the two numbers that are hidden.

There must be at least
one more 4.

4 5 4 6 3 x

The numbers must add to $5 \times 6 = \underline{\underline{30}}$

$$4 + 5 + 6 + 3 + 4 = 22$$

$$30 - 22 = 8$$

.....
4 , 8
.....
(2)

(Total for question 8 is 3 marks)

9 Here is a list of numbers.

14 19 15 20 11 14 19

(a) Find the range

$$20 - 11 = 9$$

(b) Calculate the mean

$$14 + 19 + 15 + 20 + 11 + 14 + 19 = 112$$

$$\frac{112}{7} = 16$$

9

(2)

16

(2)

Andrew says,

"The median is the middle number, so the median is 20."

(c) Andrew is incorrect, explain why.

11 14 14 15 19 19 20
↑

The numbers have to be ordered first.

The median is 15.

(1)

(Total for question 9 is 5 marks)

10 Here is a list of seven numbers.
One of the numbers is hidden.

11	6	7	10	7	9	?
----	---	---	----	---	---	---

The mean of the numbers is 9.

Find the value of the hidden number.

$$7 \times 9 = 63 \quad \text{The numbers must add to } 63$$

$$11 + 6 + 7 + 10 + 7 + 9 = 50$$

$$63 - 50 = 13$$

13

(Total for question 10 is 2 marks)

- 11 The mean of eight numbers is 41.
The mean of two of the numbers is 29.
Work out the mean of the other six numbers.

$$8 \times 41 = 328 \quad \text{All numbers total } 328$$

$$2 \times 29 = 58 \quad \text{Two numbers total } 58$$

$$328 - 58 = 270$$

$$\frac{270}{6} = 45$$

..... 45

(Total for question 11 is 3 marks)

- 12 Mark ran a mean distance of 13.2 km in five days.

The next day Mark ran 20 km.

Find the mean distance Mark ran in the six days.

$$13.2 \times 5 = 66 \text{ km in } 5 \text{ days}$$

$$66 + 20 = 86 \text{ in } 6 \text{ days}$$

$$\frac{86}{6} = 14.\dot{3} \text{ km}$$

..... 14. $\dot{3}$ km

(Total for question 12 is 3 marks)

